

**This is  
not a  
catalog**

# This is not a catalog

# manifesto

COMPANY

AZIENDA

VOLUME 7.0

4

INNOVA

Work now occupies much of our lives. This is why we love building projects and true relationships with our clients. A strong and positive relationship between client and company is one of our primary goals. This is the only way we can achieve the best result in every project and have some fun while working.

#### Relazioni Umane/

Oggi giorno il lavoro impegna gran parte della nostra vita. Per questo ci piace costruire progetti e relazioni vere con i nostri clienti.

Una relazione forte e positiva tra cliente e azienda è uno dei nostri primi obiettivi. Solo così possiamo ottenere il risultato migliore in ogni progetto e anche divertirci mentre lavoriamo.

HUMAN  
RELATIONSHIPS

01

Innova isn't a traditional furniture company. We are more than just the so-called good and beautiful Made in Italy. While the Made in Italy is certainly an added value to our work, it's not the main one.

#### Non solo Made in Italy/

Innova non è una tradizionale azienda d'arredamento. Siamo di più del solo e tanto nominato Made in Italy. Il Made in Italy rappresenta di certo un valore aggiunto per la nostra azienda, ma non è il principale mentre lavoriamo.

MORE THAN  
MADE IN ITALY

02

We act ethically. Always, working inside the company and in our private lives. More than a list of rules and principles, it is a true moral code. It is a force that drives us toward a healthy and pure business.

#### Etica & Onestà/

Agiamo secondo etica. Sempre, quando siamo all'interno dell'azienda e nelle nostre vite private. Non si tratta di una lista di regole e principi, è proprio un codice morale. È una forza che ci spinge a un business sano e puro.

ETHIC &  
HONESTY

03

We are a family company, founded by Livio Moro, and with a very low staff turnover. This strong bond, almost like a family, exists among colleagues, but also with our partners. Kindness, friendliness and transparency are at the base of our way of working and creating relations. Obviously, these values must be mutual.

#### Famiglia/

Siamo un'azienda familiare, fondata da Livio Moro, con un bassissimo ricambio di persone. Questo legame forte, quasi familiare, è vivo tra colleghi, ma anche con i nostri partner. Gentilezza, cordialità e chiarezza sono alla base del nostro modo di lavorare e di creare relazioni. Ovviamente, questi valori devono essere reciproci.

THE FAMILY

04

Innova has been operating in the furniture industry since 1982. We have a great deal of experience and a persistently fresh way of thinking. Cultivating this fresh way of thinking is the building block of any innovative company. Always one step ahead.

#### Freschezza di pensiero/

Siamo attivi nel settore dell'arredamento dal 1982. Uniamo grande esperienza e un'irrefrenabile freschezza di pensiero. Coltivare un modo di pensare fresco caratterizza le fondamenta di un'azienda innovativa, sempre un passo avanti.

FRESH  
THINKING

05

In this field, we are old-fashioned. Holding true to our words is at the root of our way of working. Our words, like a handshake, have the power to build relations founded on trust.

#### Essere di parola/

In questo caso, siamo all'antica. Per noi essere di parola è alla radice nel nostro modo di lavorare. Una parola, quanto una stretta di mano, hanno la forza per costruire relazioni di fiducia.

TRUE TO  
OUR WORDS

06

VOLUME 7.0

5

INNOVA

## Bespoke thinking

### Infinite choice of fabrics

All Innova products can be customised thanks to a choice of fabrics, selected from our vast range or supplied directly by our clients.

**Infinite possibilità di tessuti/** Tutti i prodotti di Innova possono essere personalizzati con finiture di tessuto a piacere, scelte fra la vasta selezione interna di tessuti o fornite dal cliente.

### Not just standard

We are the number one fan of our clients. We love listening to their ideas and thinking precisely; for us this means creating the chairs, sofas, footstools and headboards imagined by (and often with) them.

**Non solo standard/** Siamo i primi fan dei nostri clienti. Amiamo ascoltare le loro idee e pensare preciso: per noi vuol dire creare proprio quelle poltrone, quei divani, quei pouf, quelle testiere immaginate da (e con) loro.

### Numerous services

We live in a world in which services have become more important than products. For this reason we pay a great deal of attention.

**Numerosi servizi/** Viviamo in un mondo dove i servizi sono diventati più importanti dei prodotti, per questo motivo ci mettiamo davvero molta attenzione.

### On time

Production times have to be respected because we divide our projects into individual phases, each with its own deadline, while working with an overall vision.

**Occhio alla puntualità/** I tempi di realizzazione sono rispettati perché dividiamo i progetti in singole fasi, ognuna con la sua scadenza, e ragioniamo con una visione d'insieme.

### Value of relationships

We consider good relationships a value that empowers those who cultivate them. We pursue good relations with both our clients and suppliers; both are extremely important to the lifecycle of any product.

**Valore alle relazioni/** Consideriamo le buone relazioni un valore che dà potere a chi le coltiva. Puntiamo a relazioni di valore sia con i clienti che con i fornitori; entrambi sono estremamente importanti nel ciclo di vita del prodotto.

### Attentive Listeners

Every project begins with good listening. It is truly important for us to precisely understand the requests made by our clients in order to reach consistently better results.

**Ascolto attento/** Ogni buon progetto parte sempre da un buon ascolto. Per noi è davvero importante capire esattamente le richieste del cliente affinché il risultato sia migliore.

# 1.760.261

**People sit in our product**

Persone sedute nei nostri prodotti

# 72.400 m

**Stiching in a year**

Metri di cucitura annui

# 61.250 m

**Fabrics cut per year**

Tessuto tagliato all'anno

# 13.105

**Items made every year**

I pezzi prodotti all'anno

# 1207

**Facilities with our products**

Strutture ricettive con i nostri prodotti

# 1982

**Foundation year**

Anno di fondazione

# 3.800 mq

**Manufacturing area**

I metri quadri produttivi dell'azienda

# 27

**Countries where we exported**

I paesi in cui esportiamo i nostri prodotti

## How many countries do our products get exported to?

In quanti paesi vengono esportati  
i nostri prodotti?

## What year was Innova founded?

In che anno viene fondata Innova?

## How many meters are sewn per year?

Quanti metri all'anno vengono cuciti?

## How many people does sit in our products?

Quante persone si siedono nei nostri prodotti?

# the founder

LIVIO MORO



**Incontrare il diverso è un'opportunità per mettersi in discussione. Persistere nell'affrontare un ostacolo ti ipnotizza, ma cambiando prospettiva, spesso è possibile superarlo.**

Encountering the different is an opportunity to challenge oneself. Persisting in facing an obstacle mesmerizes you, but by changing perspective, it's often possible to overcome it.

**MANY PEOPLE  
TELL YOU WHAT  
YOU CAN OR  
CANNOT DO.**

**HERE AT INNOVA,  
WE GIVE YOU THE  
OPPORTUNITY  
TO RANGE.**

**MOLTI TI DICONO  
COSA PUOI O  
NON PUOI  
FARE.**

**NOI AD INNOVA  
TI DIAMO LA  
POSSIBILITA'  
DI SPAZIARE.**

This is why we define ourselves as “producers of white pages”, sheets that are drawn and coloured from your ideas. We can create the product with the style you imagined, from fabric to finishing, or even designed from your sketch. Thank to our experience, we will drive you throughout the whole manufacturing process.

Per questo ci definiamo “produttori di pagine bianche”, fogli che vengono disegnati e colorati dalle tue idee. Siamo in grado di confezionare il prodotto dello stile che vi immaginate, dal tessuto alla finitura, o anche disegnato da zero partendo dai vostri schizzi. Grazie alla nostra esperienza ti accompagneremo lungo tutto il processo di realizzazione.

**We are makers  
of blank pages.**

“Siamo produttori di pagine bianche.”

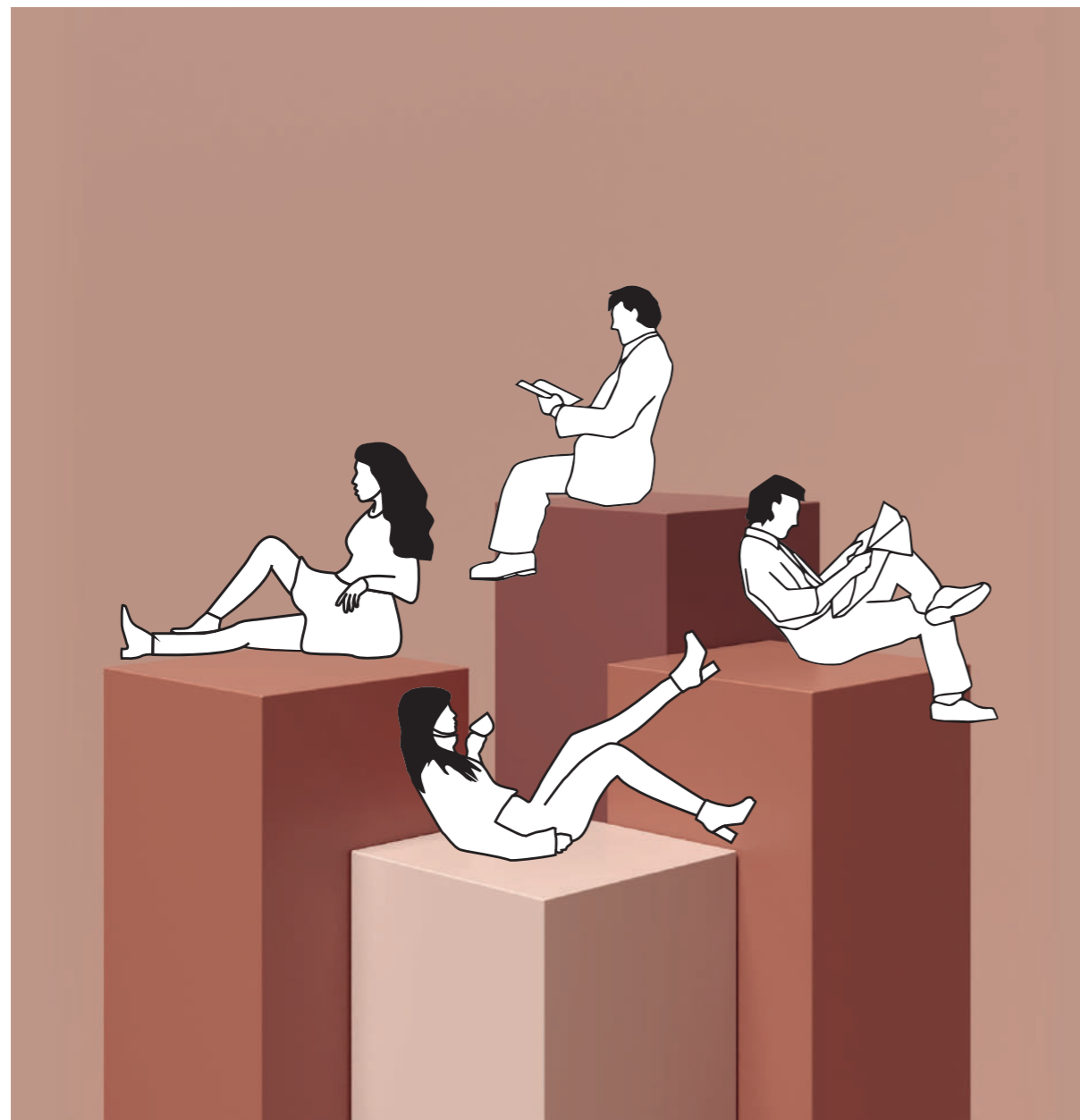

# usability

What is the most comfortable way to experience a product?  
This is difficult to understand from photographs, but simple using our indicators.  
We can immediately reveal their meaning and help you understand them right away.

Come è più comodo da vivere un prodotto?  
Difficile capirlo dalle foto, semplice con i nostri indicatori.  
Ti sveliamo il loro significato e capirai al volo i prodotti.

## How we design products



### **R** Regular seating *Seduta regolare*

A seat that helps you assume a composed stand, with a straight back, respecting all the rules of good etiquette.

È una seduta che ti accompagna ad assumere una posizione composta, con la schiena dritta, degna del galateo.

### **L** Lounge seating *Seduta comoda*

Here you can stretch out and relax a little bit, while maintaining the necessary "decorum".

Qui puoi allungarti e rilassarti un po', mantenendo ancora il cosiddetto un di "decoro".



### **C** Chill seating *Seduta spensierata*

We reach another level. Unplug and think about what you want, in freedom!

Passiamo a un altro livello. Stacca la spina e pensa a ciò che vuoi, in libertà!

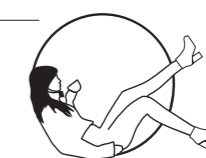

### **B** Bold seating *Seduta sfacciata*

Grandma wouldn't approve... But it's so comfortable and inviting, to be interpreted as one wishes.

La nonna non approverebbe... Però è tutto comodo e invitante, da interpretare a piacere.

**CHAIRS**

Arena	22
Bands & Bands Arm	36
Ellie	50
Izzy & Izzy Open	24
Matt	48
Opera & Opera Arm	26
Soho & Soho Arm	28
Twiggy & Twiggy Arm	38

**Dining chair**

Athena	46
Eleven & Eleven Arm	40
Heo	30
Mies & Mies Arm	44
Rivoli Arm	34
Rivoli Tall & Short	32
Twin & Twin Arm	42

**ARMCHAIRS**

Art	60
Bloom	72
Diamond	62
Kat	98
Kuma & Kuma Open	66
Look & Look Open	64
Noem	96
Olie	76
Poison	94
Thea	70
Woody	84

**Lounge**

Adam	110
Adam High	112
Arsenale Bergère	142
Arsenale GL1	140
Arsenale LC1	138
Bands Bergère	116
Bands Lounge	114
Berg High	120

Berg Low	118
Bisy	108
Bloom Lounge	74
Circus High	132
Circus Low	130
Crabby	154
Curvy	80
Dahlia	82
Eleven	134
Kyo	136
Look Lounge	100
Lucy & Justin	150
Merge	152
Mella	148
Nobu	146
Olie Lounge	78
Otta	144
Smoky High	106
Smoky Low	102
Smoky Medium	104
Tera	68
Woody Lounge	86

**SOFAS**

Adam 2/3 seaters	163
Arsenale GL1	171
Arsenale LC1	174
Berg	169
Brezza	179
Brezza XL	181
Circus High	177

Circus Low	175
Kat	167
Kyo	148
Mella	189
Noa	183
Nobu	187

**NOT ORDINARY**

Macaron	199
Mella	203
Moka	201

Ness	205
Vice-versa	207

**BARSTOOLS**

Diamond	219
Izzy & Izzy Open	220
Look	221

Ness	222
Rivoli	223
Soho	224

**COMPLEMENTS****Pouf**

Adam	229
Berg	230
Cloud	230
Drum	229
Gin	228
Macaron	228
Merge	233
Moka	232
Neep & Noop	233
Ness	233
Sky	230
Taco	229
Tonic	228
Vice-versa	231
Cushions/ Cuscini	234

**Tables**

Gio	247
Levante	245
Moka	242
Ness	250
Rosie	246
Talino	249
Tala	251
Tube	243
Tulu	244

**Carpet**

Airy	253
Dori	254

**DESIGN & TECHNICAL BOOK**

Company \ Azienda	4
Design feel\ Designers	267

Families\ Famiglie	255
Finishing\ Finiture	262

Near tables and coffee tables in cafes and restaurants, to the desk or at the meeting table, in a hotel room or in a meeting room.

Wherever they are placed, it is important that chairs are stable and comfortable. Innova presents a complete and versatile collection of seats. They are all customizable, since each shell, always padded and upholstered with fabric, can be combined with the different bases available, choosing between wood or metal structures, and among different shapes, from the most classical to the most modern one.

Accanto a tavoli e tavolini di caffè e ristoranti, alla scrivania o al tavolo da riunione, in una camera d'albergo o in una sala conferenze. Qualunque sia la loro destinazione, è importante che le sedie siano solide e comode.

Innova propone una collezione completa e versatile di sedute. Sono tutte personalizzabili, perché offrono la possibilità di abbinare ogni scocca, sempre imbottita e rivestita in tessuto, con i diversi basamenti disponibili, scegliendo tra legno o metallo e tra molte forme, dalla più classica alla più moderna.

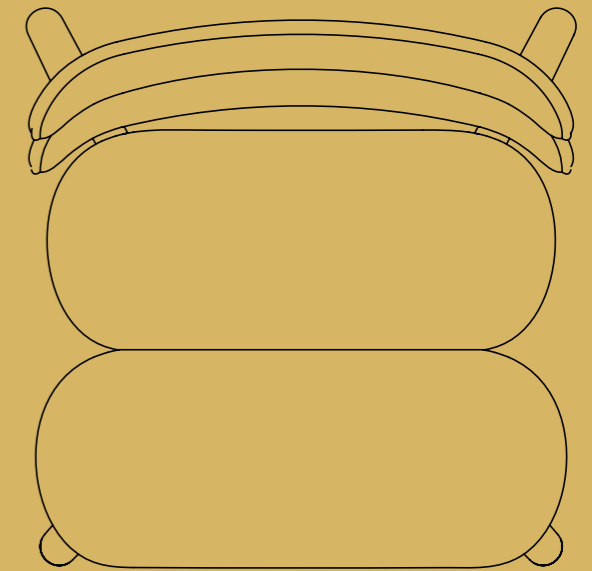
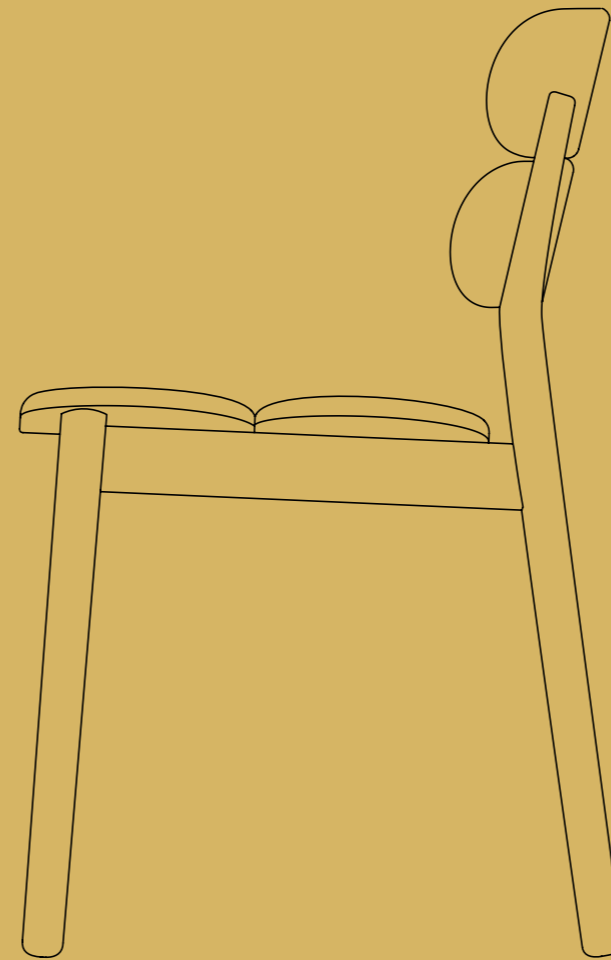

# chairs

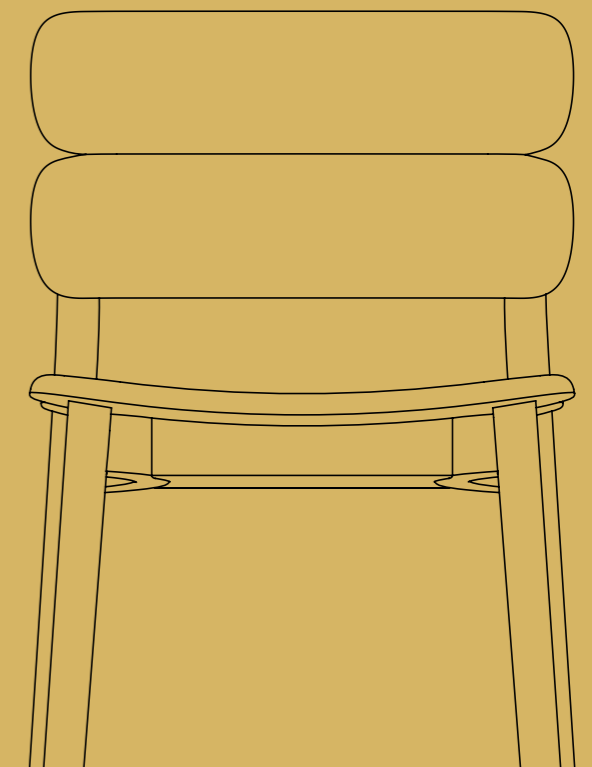

# Arena

CHAIRS

VOLUME 7.0

22

INNOVA



ARENA GL

SEDIE

## Bases



C1



P2 (fissa /fixed)  
P10 (girevole/swivelling)



L7



L17



R15



N1R



N1



R1

VOLUME 7.0

23

INNOVA

Regardless of the legs or base selected, the profile of this model remains unmistakable: open, inviting and reminiscent of a classical amphitheatre.

Qualsiasi siano le gambe o il basamento scelto, il profilo di questo modello è inconfondibile: aperto e accogliente, ricorda un anfiteatro classico.



ARENA GL

## Bases



L17



L9

P2 (fissa/fixed)  
P10 (girevole/swivelling)

S3



R15



N1



NIR



R1



A chair with soft shapes and an essential profile. It can be personalised with relief stitching upon request, different legs and bases and an added opening on the back that introduces a touch of lightness.

Una sedia dalle forme morbide e dal profilo essenziale. È personalizzabile con cuciture a rilievo su richiesta, con gambe e basamenti diversi e con l'apertura sulla schiena per dare un tocco di leggerezza.

FAMILY PRODUCT

Izzy  
& IZZY OPEN



FROM LEFT IZZY L17 AND IZZY OPEN C1

# Opera

& OPERA ARM

CHAIRS

VOLUME 7.0

26

INNOVA



FROM LEFT OPERA ARM AND OPERA

SEDIE

VOLUME 7.0

27



The modern techniques of production open the possibility to details and new forms that transform a classic chair in a piece of design by strong personality.

Le moderne tecniche di produzione aprono la possibilità a dettagli e forme nuove che trasformano una sedia classica in un pezzo di design dalla forte personalità.



CHAIRS

SEDIE

# Soho

& SOHO ARM

VOLUME 7.0



VOLUME 7.0

28



29



INNOVA

There is only one mantra for Soho: freedom, vivacity, youth and freshness. The clean structure of the base embraces the backrest... it is a play of contrasts between fabric and wood. Striking!

C'è un solo mantra, per Soho: libertà, vivacità, giovinezza e freschezza. La struttura pulita della base abbraccia lo schienale... è un gioco di contrasti fra tessuto e legno. D'impatto!

FAMILY PRODUCT

FROM LEFT SOHO ARM AND SOHO

# Heo

DINING CHAIRS

VOLUME 7.0

30

INNOVA



SEDIE DA PRANZO

VOLUME 7.0

31

INNOVA



Shapes so simple they become unique.  
Heo is soft and welcomes you in a large seat.  
Perfectly in different contexts: change the fabric  
and, voila, a new product is created.

Forme talmente semplici da divenire uniche.  
Heo è morbida e accogliente in un'ampia seduta.  
Perfetta in diversi contesti: cambia il tessuto e, voilà,  
un nuovo prodotto si crea.

DINING CHAIRS



VOLUME 7.0

32

INNOVA



SEDIE DA PRANZO

# Rivolí

SHORT & TALL

VOLUME 7.0

33

INNOVA



Elegant shapes and comfort to stand out.  
Fabric and wood, combined to fascinate.  
A sophisticated base that slims and provides  
security. Très chic.

Forme eleganti e comodità per distinguersi.  
Tessuto e legno, abbinati per affascinare.  
E un basamento sofisticato per slanciare  
e dare sicurezza. Très chic.

FAMILY PRODUCT

FROM LEFT RIVOLÍ SHORT AND RIVOLÍ TALL

# Rivolí

ARM

VOLUME 7.0

34

INNOVA



VOLUME 7.0

35

INNOVA



Rivolí arm is the truly comfortable choice. Its enveloping shape enriched by armrests is ideal for sophisticated dining rooms, embellished by the Parisien style.

Rivolí arm è la scelta comoda assai. La sua forma avvolgente arricchita dai braccioli è ideale per sale da pranzo sofisticate, impreziosite dallo stile Parisien.

**FAMILY PRODUCT**

CHAIRS

VOLUME 70



36

INNOVA



Bands is a chair with a simple look, yet very distinctive. The repetition of the only structural element creates the seat and the backrest, available also with armrests.

Bands è una sedia dall'aspetto semplice eppure molto riconoscibile. La ripetizione di un unico elemento accoppiato crea sedile e schienale, anche con braccioli.

FAMILY PRODUCT

SEDIE

# Bands

& BANDS ARM

VOLUME 70

37

INNOVA



FROM LEFT BANDS ARM AND BANDS

# Twiggy

& TWIGGY ARM

VOLUME 7.0

38

INNOVA

CHAIRS



FROM LEFT TWIGGY ARM N1 AND TWIGGY L12

SEDIE

## Bases



L7



L17



L12



P2 (fissa/fixed)  
P10 (girevole/swivelling)



C1



R15



R1



P9

VOLUME 7.0

39

INNOVA

Our Twiggy is ironic and elegant. It has different bases, thin and slender, and a seat with or without armrests, always with a pop opening.

La nostra Twiggy è ironica ed elegante. Propone diversi basamenti, sottili e slanciati, e una seduta con o senza braccioli, sempre con un'apertura pop.



# Bases



L17



R1



R15



P2 (fissa/ fixed)  
P10 (girevole/ swivelling)



C1



N1



N1R

VOLUME 70

40

INNOVA



Soft drapes and immediate comfort: these are what distinguishes the Eleven collection. From armchairs to dining chairs, small and practical to fill any room.

Drappeggi morbidi e confortevolezza immediata: è questo che contraddistingue la collezione Eleven. Dalla poltrona alle sedie da pranzo, piccole e pratiche per riempire ogni ambiente.

FAMILY PRODUCT



# Eleven

& ELEVEN ARM

VOLUME 70

41

INNOVA



FROM LEFT ELEVEN ARM L17 AND ELEVEN P2

# Twin

& TWIN ARM

VOLUME 7.0

42

INNOVA



FROM LEFT TWIN L13 AND TWIN ARM R1

DINING CHAIRS



SEDIE DA PRANZO

## Bases



L13



L17



R1



R15



N1R



N1



C1



P2 (fissa/fixed)  
P10 (girevole/swivelling)

VOLUME 7.0

43

INNOVA



The rigid backrest coupled with the soft padding plays the main role in the Twin collection. It leaves the freedom to combine contrasting colours and finishes or to match them.

Lo schienale rigido accoppiato con l'imbottitura morbida diventa protagonista nella collezione Twin. Lascia la libertà di combinare colori e finiture a contrasto o in abbinamento tra di loro.

DINING CHAIRS



VOLUME 70

44



A tribute to a great master: essentiality and simplicity characterise the repeated rays of the structure and the illusion of a suspended seat.

Un omaggio a un grande maestro: essenzialità e semplicità caratterizzano i raggi ripetuti della struttura e l'illusione della sospensione della seduta.

SEDIE DA PRANZO

# Mies

& MIES ARM



VOLUME 70

45



INNOVA

INNOVA

FROM LEFT MIES ARM AND MIES

# Athena

DINING CHAIRS

VOLUME 70

46

INNOVA



SEDIE DA PRANZO



47

INNOVA



Athena is sensuality and strength at the same time. The frame with soft but decisive shapes supports the seat and the sinuous backrest.

Athena è sensualità e allo stesso tempo forza. Il telaio dalle forme morbide ma decise sorregge la seduta e lo schienale sinuoso.

CHAIRS

VOLUME 70



48



INNOVA



Dream of flying, albeit looking at reality and finding its beauty in the simplicity of every day. Matt is enveloping and daily, just like the beauty that lies in simplicity.

Sognare di volare, seppur guardando la realtà e trovandone la bellezza nella semplicità di ogni giorno. Matt è avvolgente e quotidiano, proprio come la bellezza che risiede nella semplicità.

SEDIE

# Matt

VOLUME 70

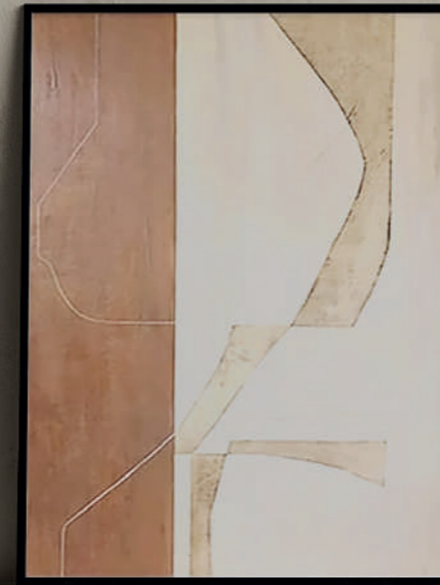

49



INNOVA

# Ellie

CHAIRS

VOLUME 7.0

50

INNOVA



SEDIE

VOLUME 7.0

51

INNOVA



Ellie has a soft yet sharp design, it doesn't go unnoticed. Two personalities, two types of curves that blend together in a pointed design with its intersection of im-perfect forms.

Ellie ha un design morbido ma tagliente, non passa inosservata. Due personalità, due tipi di curve che si fondono insieme in un design pungente nella sua intersezione di forme in-perfette.

# Reference



Mies

NH Buenos Aires

## Arena

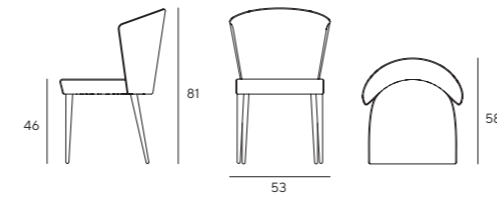

## Opera

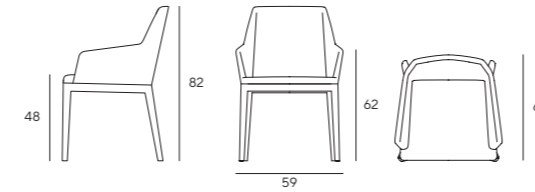

## Heo

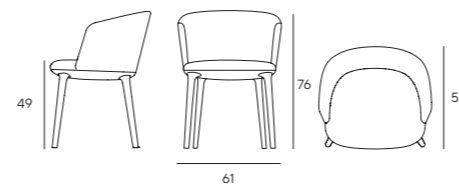

## Bands

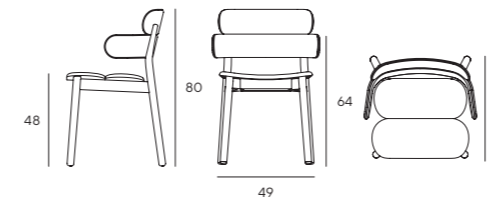

## Eleven

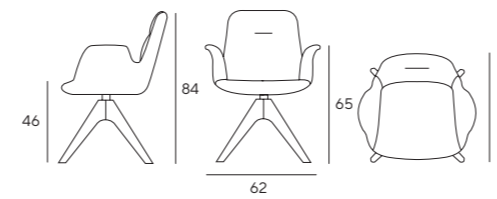

## Mies

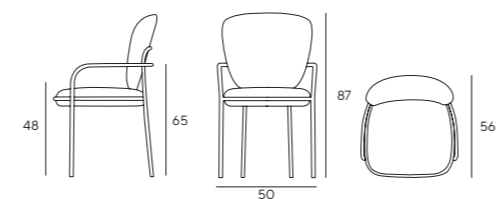

## Ellie

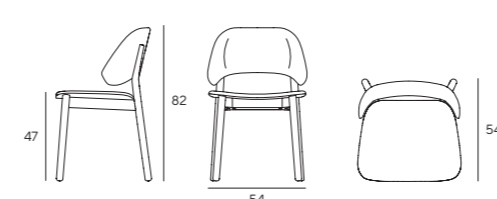

## Izzy

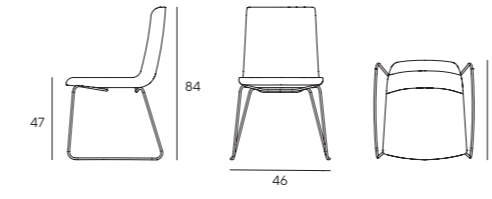

## Soho

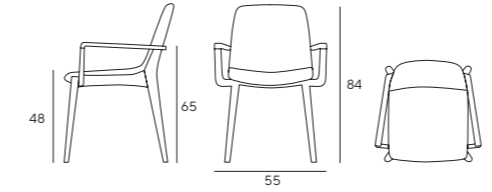

## Rivoli Short, Tall and Arm

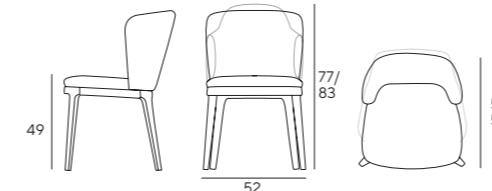

## Twiggy

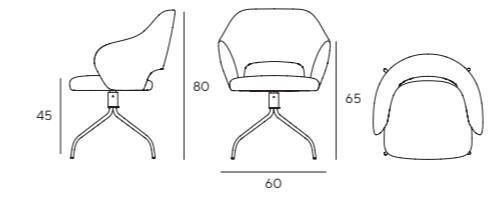

## Twin

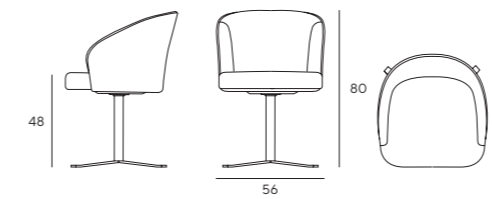

## Athena

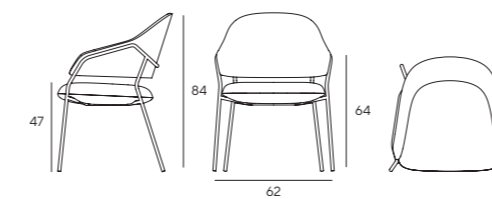

## Matt

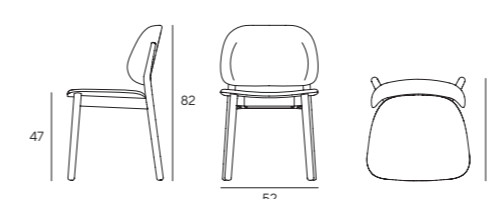

## Arena

**Composition:** Steel framework, entirely moulded in cold-cure polyurethane.  
**Composizione:** Struttura della scocca in acciaio, interamente stampata in poliuretano schiumato a freddo.  
**Weight / Peso:** from 7 to 13 kg  
**Required fabric / Tessuto occorrente:** 1,20 m. (h 1,40).

## Opera

**Composition:** Steel framework, entirely moulded in cold-cure polyurethane with ash wood base.  
**Composizione:** Struttura della base in acciaio, interamente stampata in poliuretano schiumato a freddo con basamento in legno di frassino.  
**Weight / Peso:** Opera 10 kg - Opera Arm 12 kg  
**Required fabric / Tessuto occorrente:** Opera 1,10 m. (h 1,40)  
 Opera Arm 1,50 m. (h 1,40).

## Heo

**Composition:** Entirely moulded in cold-cure polyurethane.  
**Composizione:** Interamente stampata in poliuretano schiumato a freddo.  
**Weight / Peso:** 7,5 kg  
**Required fabric / Tessuto occorrente:** 1,50 m. (h 1,40).

## Bands

**Composition:** Solid beech wood structure, backrest and seat in curved plywood with expanded polyurethane foam, upholstered with fabric.  
**Composizione:** Struttura della base in massello di faggio, schienale e seduta in multistrato curvato, imbottiti con poliuretano espanso a quote differenziate, rivestiti in tessuto.  
**Weight / Peso:** from 7 to 8 kg  
**Required fabric / Tessuto occorrente:** Bands 1,60 m. (h 1,40).  
 Bands Arm 2,50 mt. (h 1,40).

## Eleven

**Composition:** Steel framework, entirely moulded in cold-cure polyurethane.  
**Composizione:** Struttura della scocca in acciaio, interamente stampata in poliuretano schiumato a freddo.  
**Weight / Peso:** from 8 to 12 kg  
**Required fabric / Tessuto occorrente:** Eleven 1,30 m. (h 1,40)  
 Eleven Arm 1,70 m. (h 1,40).

## Mies

**Composition:** Metal structure, backrest and seat in curved plywood with expanded polyurethane foam.  
**Composizione:** Struttura della base in metallo, schienale e seduta in multistrato e curvato imbottiti con poliuretano espanso.  
**Weight / Peso:** 10 kg  
**Required fabric / Tessuto occorrente:** 1,40 m. (h 1,40).

## Ellie

**Composition:** Solid beech wood structure, backrest and seat in curved plywood with expanded polyurethane foam, upholstered with fabric.  
**Composizione:** Struttura della base in massello di faggio, schienale e seduta in multistrato curvato, imbottiti con poliuretano espanso, rivestiti in tessuto.  
**Weight / Peso:** 7 kg  
**Required fabric / Tessuto occorrente:** 1,60 m. (h 1,40).

## Izzy

**Composition:** Steel framework, entirely moulded in cold-cure polyurethane.  
**Composizione:** Struttura della scocca in acciaio, interamente stampata in poliuretano schiumato a freddo.  
**Weight / Peso:** from 7 to 13 kg  
**Required fabric / Tessuto occorrente:** 1,10 m. (h 1,40).

## Soho

**Composition:** Solid beech wood structure, backrest and seat in curved plywood with expanded polyurethane foam, upholstered with fabric.  
**Composizione:** Struttura della base in massello di faggio, schienale e seduta in multistrato curvato, imbottiti con poliuretano espanso, rivestiti in tessuto.  
**Weight / Peso:** 6 kg  
**Required fabric / Tessuto occorrente:** 1,10 mt. (h 1,40).

## Rivoli Short, Tall and Arm

**Composition:** Ash wood structure, backrest and seat in curved plywood with expanded polyurethane foam, upholstered with fabric.  
**Composizione:** Struttura della base in massello di faggio, schienale e seduta in multistrato curvato, imbottiti con poliuretano espanso, rivestiti in tessuto.  
**Weight / Peso:** Rivoli Short 5 kg - Rivoli Tall 5,5 kg - Rivoli Arm 6,5 kg  
**Required fabric / Tessuto occorrente:** Rivoli Short 1,10 m. (h 1,40)  
 Rivoli Tall 1,10 m. (h 1,40) Rivoli Arm 1,70 (h 1,40)

## Twiggy

**Composition:** Steel framework, entirely moulded in cold-cure polyurethane.  
**Composizione:** Struttura della scocca in acciaio, interamente stampata in poliuretano schiumato a freddo.  
**Weight / Peso:** from 9 to 15 kg  
**Required fabric / Tessuto occorrente:** Twiggy 1,30 m. (h 1,40)  
 Twiggy arm 1,50 m. (h 1,40).

## Twin

**Composition:** Structure entirely moulded in flexible polyurethane, backrest with varnished rigid polyurethane insert. Expanded polyurethane seat with wooden frame.  
**Composizione:** Struttura stampata interamente in poliuretano flessibile, schienale con inserto in poliuretano rigido verniciato. Sedile in poliuretano espanso con struttura in legno.  
**Weight / Peso:** Twin from 8 to 13 kg, Twin Arm from kg 10 to 15  
**Required fabric / Tessuto occorrente:** Twin 1,20 m. (h 1,40)/  
 Twin Arm 2,00 m. (1,40)

## Athena

**Composition:** Metal varnished frame, supporting structure in rigid polyurethane with ultra soft expanded polyurethane foam.  
**Composizione:** Basamento in metallo verniciato, struttura portante in poliuretano rigido con imbottitura in poliuretano espanso ultra soft.  
**Weight / Peso:** 9 kg  
**Required fabric / Tessuto occorrente:** 1,50 m. (h 1,40).

## Matt

**Composition:** Solid beech wood structure, backrest and seat in curved plywood with expanded polyurethane foam, upholstered with fabric.  
**Composizione:** Struttura della base in massello di faggio, schienale e seduta in multistrato curvato, imbottiti con poliuretano espanso, rivestiti in tessuto.  
**Weight / Peso:** 7 kg  
**Required fabric / Tessuto occorrente:** 1,60 m. (h 1,40).

**Arena**

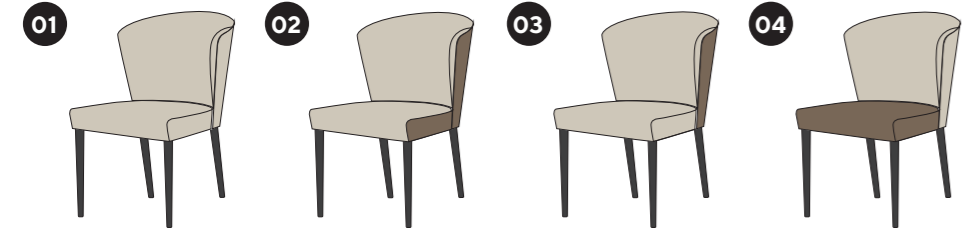

- Option 1**  
unique fabric
- Option 2**  
one fabric for the inner part and another for the outside
- Option 3**  
one fabric for the outside backrest and another for the rest
- Option 4**  
one fabric for the seat another for the backrest



**Rivoli Arm**



- Option 1**  
unique fabric
- Option 2**  
one fabric for the outside backrest and another for the rest
- Option 3**  
one fabric for the seat another for the backrest



**Athena**



- Option 1**  
unique fabric
- Option 2**  
one fabric for the outside backrest and another for the rest
- Option 3**  
one fabric for the seat another for the backrest
- Option 4**  
two different mixed fabrics

**Izzy**



- Option 1**  
unique fabric
- Option 2**  
one fabric for the inner part and another for the outside



**Bands**



- Option 1**  
unique fabric
- Option 2**  
one fabric for the outside backrest and another for the rest
- Option 3**  
one fabric for the seat another for the backrest
- Option 4**  
two different mixed fabrics



**Ellie**



- Option 1**  
unique fabric
- Option 2**  
one fabric for the outside backrest and another for the rest
- Option 3**  
one fabric for the seat another for the backrest



**Opera**

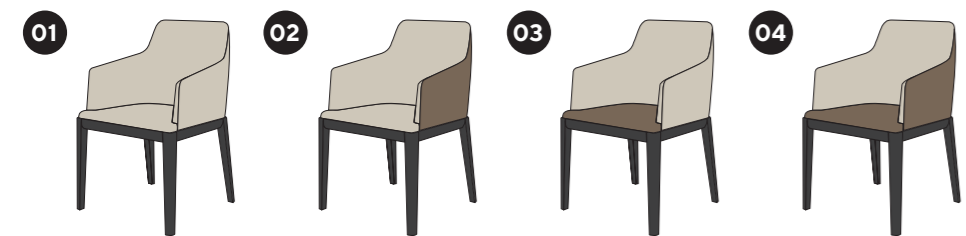

- Option 1**  
unique fabric
- Option 2**  
one fabric for the inner part and another for the outside
- Option 3**  
one fabric for the seat another for the backrest
- Option 4**  
two different mixed fabrics



**Twiggy**



- Option 1**  
unique fabric
- Option 2**  
one fabric for the outside backrest and another for the rest
- Option 3**  
one fabric for the seat another for the backrest
- Option 4**  
two different mixed fabrics



**Matt**



- Option 1**  
unique fabric
- Option 2**  
one fabric for the outside backrest and another for the rest
- Option 3**  
one fabric for the seat another for the backrest



**Soho**



- Option 1**  
unique fabric
- Option 2**  
one fabric for the inner part and another for the outside



**Eleven**

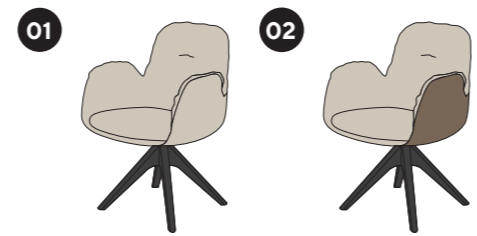

- Option 1**  
unique fabric
- Option 2**  
one fabric for the inner part and another for the outside



**Heo**

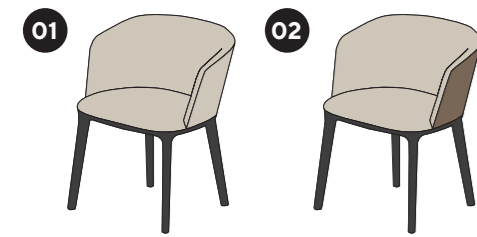

- Option 1**  
unique fabric
- Option 2**  
one fabric for the outside backrest and another for the rest



**Twin**

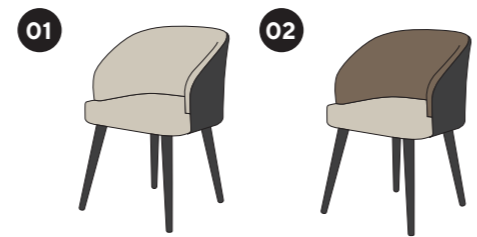

- Option 1**  
unique fabric
- Option 2**  
one fabric for the seat another for the backrest

**Rivoli Short & Tall**



- Option 1**  
unique fabric
- Option 2**  
one fabric for the outside backrest and another for the rest
- Option 3**  
one fabric for the seat another for the backrest



**Mies**

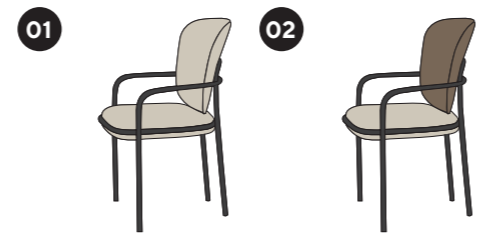

- Option 1**  
unique fabric
- Option 2**  
one fabric for the seat another for the backrest



Different shapes, colours and materials distinguish Innova's rich collection of armchairs and small armchairs.

From the classic bergère to the space-saving armchair, these padded seats are ideal for the broadest range of contract venues, from the hotel room to corporate environments, but also in domestic contexts. This is especially true of more enveloping models with footrests.

Comfortable and resistant, our armchairs can be personalised with different upholstery and a range of available bases.

Wood presents a more natural style, while metal offers a more contemporary footprint.

Forme, colori e materiali sempre diversi contraddistinguono la ricca collezione di poltrone e poltroncine di Innova. Dalla classica bergère alla poltroncina compatta, queste sedute imbottite sono ideali per i più diversi luoghi del contract, dalla camera d'albergo agli ambienti corporate, ma anche all'interno di contesti domestici; soprattutto nel caso dei modelli più avvolgenti e con poggiatesta.

Confortevoli e resistenti, le nostre poltrone si possono personalizzare con i diversi rivestimenti e le molte basi disponibili. Il legno dà uno stile più naturale, mentre il metallo offre un'impronta più contemporanea.

Pagina nel foglione

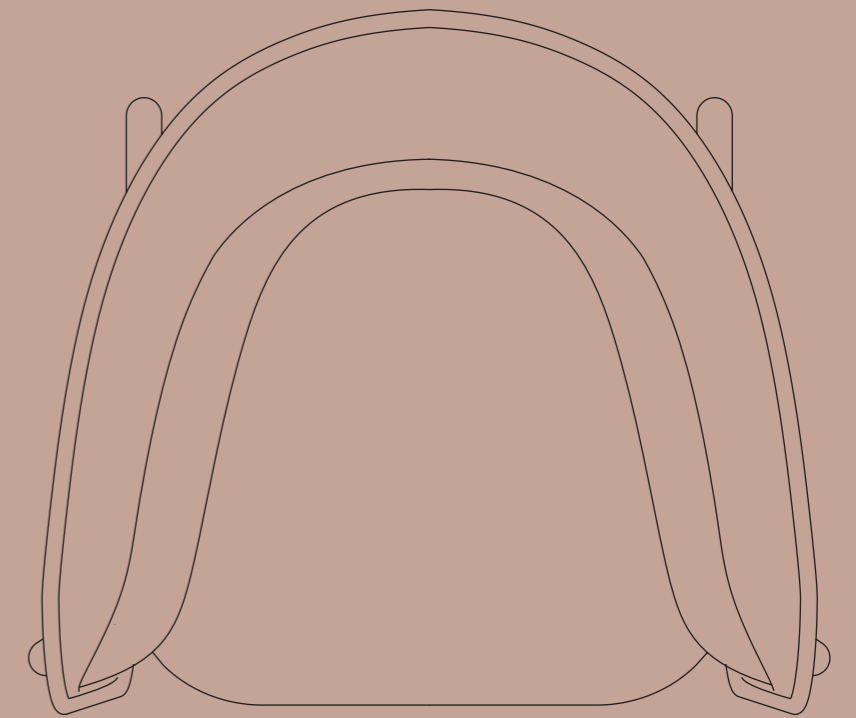
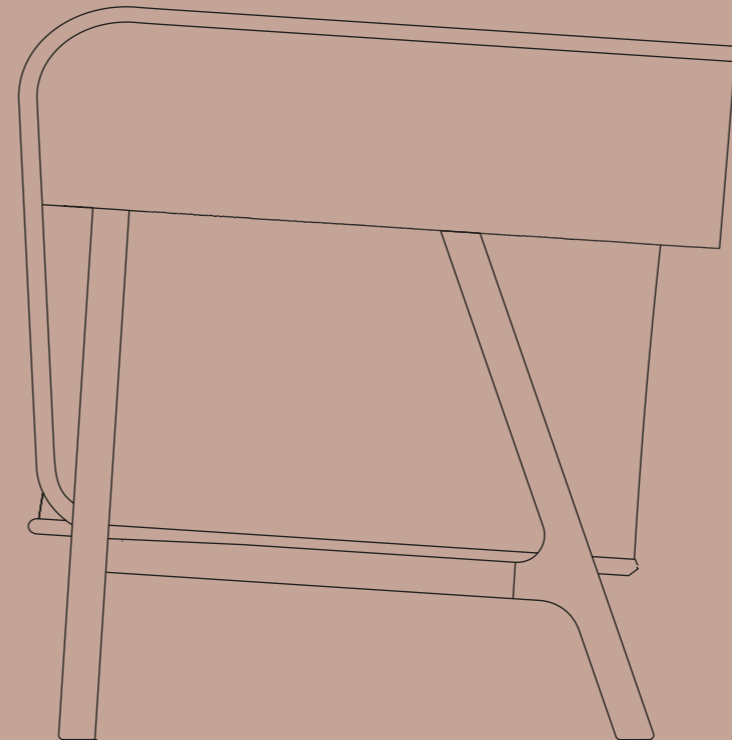

# armchairs

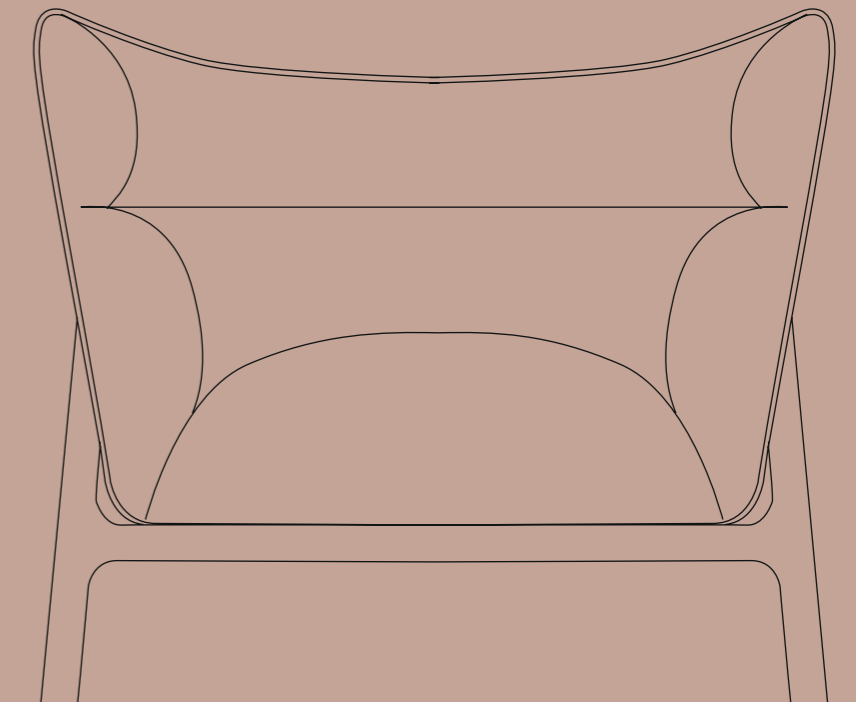

# Art

ARMCHAIRS

VOLUME 7.0

60

INNOVA



ART BLUE WITH UPHOLSTERED LEGS

POLTRONE

VOLUME 7.0

61

INNOVA



Almost a small armchair, very compact with a special care in the exposed stitching and tapered legs, finished, upon request, to become one with the back. Simply impeccable.

Quasi una poltroncina, molto compatta e curata nelle cuciture a vista e nelle gambe affusolate e rivestite, su richiesta, fino a diventare un tutt'uno con lo schienale. Impeccabile.



## Bases



R15



L17



L7



C1



P2 (fissa/ fixed)  
P10 (girevole/ swivelling)



L26



L3



N1 (no castors/ no ruote)  
N1R (with castors/ con ruote)



The strength of this chair is its small dimensions. This easy and compact armchair is also comfortable at the dining table, without occupying too much space.

Il suo punto di forza sono le dimensioni contenute. È una poltroncina comoda e compatta così è confortevole anche al tavolo da pranzo, senza occupare troppo spazio.

FAMILY PRODUCT

# Diamond



FORM LEFT DIAMOND L13 AND DIAMOND R15

# Look

ARMCHAIRS

VOLUME 70

64

INNOVA



FROM LEFT LOOK OPEN P10, LOOK S5 AND LOOK OPEN R1

POLTRONE

## Bases



L17



L3



L13



P2 (fissa/fixed)  
P10 (girevole/swivelling)



C1



R1



R15



N1 (no castors/ no ruote)  
N1R (with castors/ con ruote)

VOLUME 70

65

INNOVA



This armchair features an open form. Broad, sharp and always inviting. Different bases and legs are available in wood and metal.

Una poltroncina con una forma aperta, ampia e netta, pronta ad accogliere, da scegliere con vari basamenti e gambe in metallo o legno.

**FAMILY PRODUCT**

## Bases



L17



R1



R15



P13



C1



P2 (fissa/fixed)  
P10 (girevole/swivelling)



N1R



N1

VOLUME 7.0

66

INNOVA



Kuma is a smart product. Its shape is not intrusive, it is simple but with sinuous lines, perfect for any situation: from the office to a hall, or for a waiting room.

Kuma è un prodotto smart. La sua forma non è invadente, è semplice ma dalle forme sinuose, perfette per ogni situazione: dall'ufficio a una hall, o una waiting room.

# Kuma

& KUMA OPEN



VOLUME 7.0

67

INNOVA

FROM LEFT KUMA OPEN L17 AND KUMA P10

# Tera

LOUNGE

VOLUME 7.0

68

INNOVA



LOUNGE

## Bases



R13



L21



P29



R7

VOLUME 7.0

69

INNOVA

Curved lines that meet to create chromatic contrasts or fabric harmonies, giving free rein to creativity.

Linee curve che si incontrano per creare contrasti cromatici o armonie di tessuti, dando la possibilità alla creatività di avere libero sfogo.



ARMCHAIRS

POLTRONE

# Thea

VOLUME 70



70



INNOVA



Thea features a design with sharp lines, especially thanks to the two curves that meet as if in a hug and surround the soft and welcoming structure.

Thea presenta un design dalle linee decise, in particolare grazie alle due curve che si incontrano come in un abbraccio e circondano la struttura morbida e accogliente.

VOLUME 70

71

INNOVA



# Bloom

ARMCHAIRS

POLTRONE

## Bases



L17



L13



R1



R15



P2 (fissa/fixed)  
P10 (girevole/swivelling)



C1



N1



N1R



Sweet shapes that evoke comfort and light-heartedness. A soft shell supported by different bases: in wood for a warmer touch or in metal for a more decisive style.

Forme dolci che evocano comodità e spensieratezza. Un guscio morbido sostenuto dalle diverse basi: in legno per un tocco più caldo e in metallo per uno stile più deciso.

**FAMILY PRODUCT**

FROM LEFT BLOOM L13, BLOOM R15 AND BLOOM C1

LOUNGE

## Bases



L21



R7



C1



R13

Comfort increases in the Bloom lounge version. The backrest rises and prepares with a perfectly shaped headrest and with a cushion for an extra soft seat.

Aumenta la comodità in Bloom versione lounge. Lo schienale si alza e si prepara con un poggiatesta perfettamente conformato e un cuscino per una seduta extra morbida.

FAMILY PRODUCT

LOUNGE

# Bloom

LOUNGE



VOLUME 7.0

74

INNOVA

VOLUME 7.0

75

INNOVA

FROM LEFT BLOOM LOUNGE L21, BLOOM LOUNGE R13

# Olie

ARMCHAIRS

POLTRONE

## Bases



L17



R15



P2 (fissa / fixed)  
P10 (girevole / swivelling)



C1



R15



N1 (no castors / no ruote)  
N1R (with castors / con ruote)

VOLUME 7.0

76

INNOVA

FROM LEFT OLIE L17, OLIE R15 AND OLIE N1

VOLUME 7.0

77

INNOVA



Olie is a fun product that was born as a blank sheet... Have fun colouring it with the style and fabrics you like more.

Olie è un prodotto divertente che nasce come un foglio bianco... Divertiti tu a colorarla con lo stile ed i tessuti che più ti piacciono.

**FAMILY PRODUCT**

## Bases



L21



R7



R13



C1

Olie lounge version: more surface area, more comfort and more fun. Round and playful shapes that can be combined with different types of seats. Let yourself be transported into a world of fabrics, woods and colours.

Olie versione lounge: più superficie, più comfort e più divertimento. Forme tonde e giocose che possono essere abbinare a diverse tipologie di sedute. Lasciatevi trasportare in un mondo di tessuti, legni e colori.

FAMILY PRODUCT

# Olie

LOUNGE



# Curvy

LOUNGE

VOLUME 7.0

80

INNOVA



FROM LEFT CURVY GL AND CURVY L21

LOUNGE

## Bases



GL



L21



L31



R7



R13



S7

VOLUME 7.0

81

INNOVA



Curvy is inspired by the soft and rounded forms of the 1960s, including the elegant stitching on the back that, upon request, make the structure even more sinuous.

Curvy si ispira alle forme morbide e arrotondate degli anni sessanta, comprese le eleganti cuciture sullo schienale che, su richiesta, rendono la struttura ancora più sinuosa.

# Dahlia

VOLUME 7.0



82



INNOVA



Like two identical petals coming together on a slim yet strong stem, Dahlia has a delicate, but above all, romantic design. It symbolizes the diversity and beauty of life, inviting to sit with softness.

Come due petali identici che si uniscono su uno stelo esile ma resistente, Dahlia ha un design delicato e soprattutto romantico. Simboleggia la diversità e la bellezza della vita, invitando a sedersi con morbidezza.

VOLUME 7.0



83

INNOVA

# Woody

ARMCHAIRS

POLTRONE

## Bases



L17



R1



P2 (fissa / fixed)  
P10 (girevole / swivelling)



N1



W3



R15



C1



N1R

VOLUME 7.0

VOLUME 7.0

84

85

INNOVA

INNOVA

FROM LEFT WOODY R15 AND WOODY L17

Woody is perfect for small spaces like a reading nook or a small living room. Despite its compact dimensions, its enveloping shape provides an ideal place to relax. A cozy and comfortable addition.

Woody è perfetta per spazi piccoli come un angolo di lettura o un piccolo salotto. Nonostante le dimensioni ridotte, la sua forma avvolgente offre un luogo ideale per rilassarsi. Un'aggiunta accogliente e confortevole.

FAMILY PRODUCT



## Bases



L21



R7



W1



R13



Woody Lounge provides an extra dimension of comfort, a doubly enveloping and welcoming presence. Its soft and sinuous shapes are an irresistible invitation to take a break, immersing oneself in the warmth and in the embrace of the product.

Woody Lounge offre una dimensione extra di comfort, una presenza doppiamente avvolgente e accogliente.

Le sue forme morbide e sinuose sono un invito irresistibile a concedersi una pausa, immergendosi nel calore e nell'abbraccio del prodotto.

**FAMILY PRODUCT**

# Woody

LOUNGE



# Reference



Bands & Adam

Die Hoch Königin

## Art

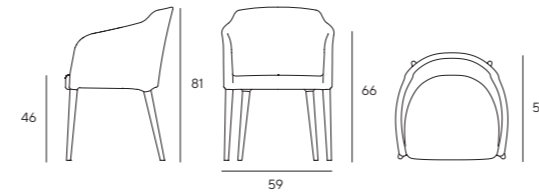

## Look & Look open

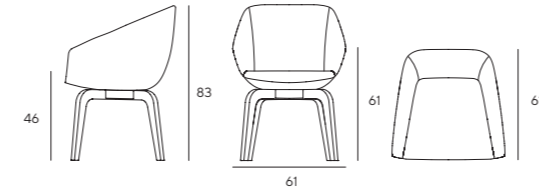

## Tera

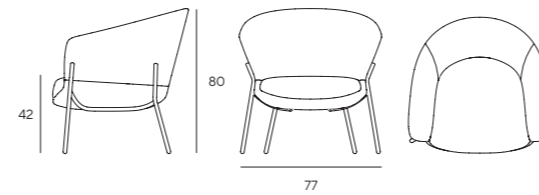

## Bloom

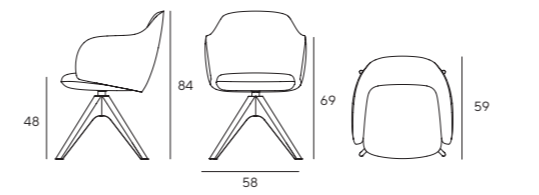

## Olie

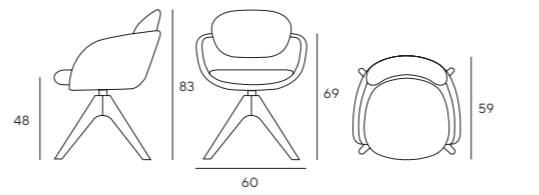

## Curvy

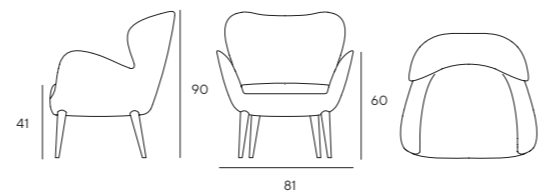

## Woody

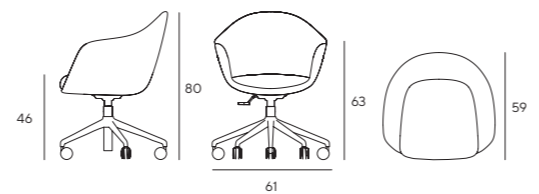

## Diamond

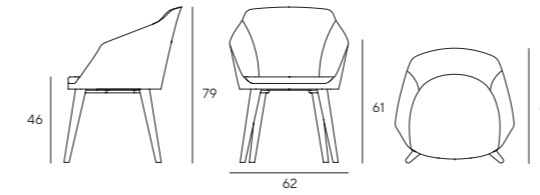

## Kuma & Kuma open

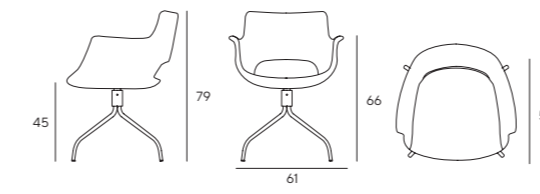

## Thea

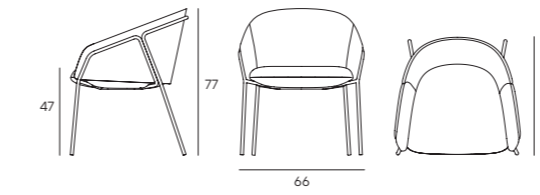

## Bloom Lounge

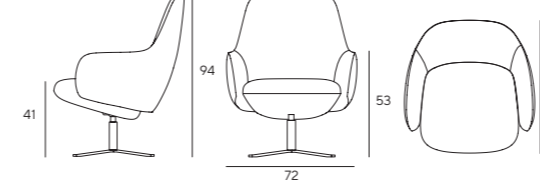

## Olie Lounge

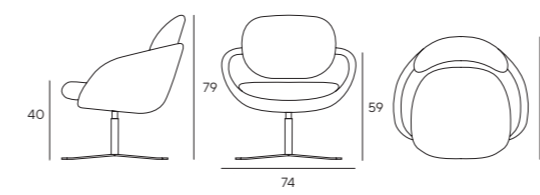

## Dahlia

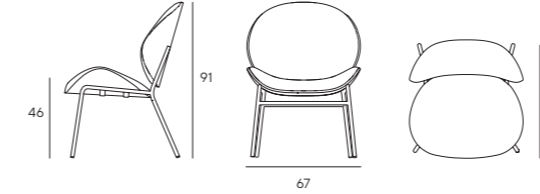

## Woody Lounge

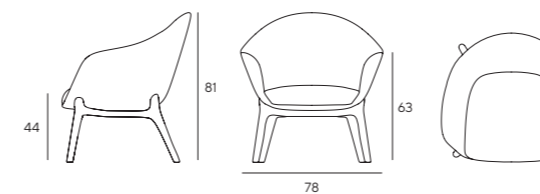

## Art

**Composition:** Steel framework, entirely moulded in cold-cure polyurethane. Legs in ash wood stained.  
The legs could be covered in fabric or leather.  
**Composizione:** Struttura in acciaio, interamente stampata in poliuretano schiumato a freddo. Gambe in legno di frassino verniciate. Le gambe possono essere rivestite in pelle o tessuto.  
**Weight / Peso:** 9 kg  
**Required fabric / Tessuto occorrente:** 1,50 m. (h 1,40).

## Look & Look open

**Composition:** Steel framework, entirely moulded in cold-cure polyurethane.  
**Composizione:** Struttura della scocca in acciaio, interamente stampata in poliuretano schiumato a freddo.  
**Weight / Peso:** from 11 to 22 kg  
**Required fabric / Tessuto occorrente:** 1,50 m. (h 1,40).

## Tera

**Composition:** Steel framework, entirely moulded in cold-cure polyurethane.  
**Composizione:** Struttura della scocca in acciaio, interamente stampata in poliuretano schiumato a freddo.  
**Weight / Peso:** from 20 to 25 kg  
**Required fabric / Tessuto occorrente:** plain colour 3,00 m. (h 1,40), bicolor 3,50 m. (h 1,40).

## Bloom

**Composition:** Supporting structure in rigid polyurethane with ultra soft expanded polyurethane foam.  
**Composizione:** Struttura portante in poliuretano rigido con imbottitura in poliuretano espanso ultra soft.  
**Weight / Peso:** from 13 to 18 kg  
**Required fabric / Tessuto occorrente:** 1,80 m. (h 1,40).

## Olie

**Composition:** Steel framework, entirely moulded in cold-cure polyurethane.  
**Composizione:** Struttura della scocca in acciaio, interamente stampata in poliuretano schiumato a freddo.  
**Weight / Peso:** from 10 to 15 kg  
**Required fabric / Tessuto occorrente:** entire product 1,70 m. (h 1,40) cushions 0,90 m. / structure 1,10 m. (h 1,40).

## Curvy

**Composition:** Steel framework, entirely moulded in cold-cure polyurethane.  
**Composizione:** Struttura della scocca in acciaio, interamente stampata in poliuretano schiumato a freddo.  
**Weight / Peso:** from 17 to 30 kg  
**Required fabric / Tessuto occorrente:** 3,50 m. (h 1,40).

## Woody

**Composition:** Structure in rigid polyurethane with ultra soft expanded polyurethane foam.  
**Composizione:** Struttura portante in poliuretano rigido con imbottitura in poliuretano espanso ultra soft.  
**Weight / Peso:** from 11 to 15 kg  
**Required fabric / Tessuto occorrente:** 1,60 m. (h 1,40).

## Diamond

**Composition:** Steel framework, entirely moulded in cold-cure polyurethane.  
**Composizione:** Struttura della scocca in acciaio, interamente stampata in poliuretano schiumato a freddo.  
**Weight / Peso:** from 11 to 22 kg  
**Required fabric / Tessuto occorrente:** 1,50 m. (h 1,40).

## Kuma & Kuma open

**Composition:** Steel framework, entirely moulded in cold-cure polyurethane.  
**Composizione:** Struttura della scocca in acciaio, interamente stampata in poliuretano schiumato a freddo.  
**Weight / Peso:** from 7 to 12 kg  
**Required fabric / Tessuto occorrente:** 1,50 m. (h 1,40).

## Thea

**Composition:** Metal varnished frame, supporting structure in rigid polyurethane with ultra soft expanded polyurethane foam.  
**Composizione:** Basamento in metallo verniciato, struttura portante in poliuretano rigido con imbottitura in poliuretano espanso ultra soft.  
**Weight / Peso:** 10 kg  
**Required fabric / Tessuto occorrente:** 1,80 mt. (h 1,40).

## Bloom Lounge

**Composition:** Supporting structure in rigid polyurethane with ultra soft expanded polyurethane foam.  
**Composizione:** Struttura portante in poliuretano rigido con imbottitura in poliuretano espanso ultra soft.  
**Weight / Peso:** from 21 to 25 kg  
**Required fabric / Tessuto occorrente:** 3,50 m. (h 1,40).

## Olie Lounge

**Composition:** Steel framework, entirely moulded in cold-cure polyurethane.  
**Composizione:** Struttura della scocca in acciaio, interamente stampata in poliuretano schiumato a freddo.  
**Weight / Peso:** from 12 to 17 kg  
**Required fabric / Tessuto occorrente:** entire product 2,50 m. (h 1,40) cushions 1,10 m. / structure 1,70 m. (h 1,40).

## Dahlia

**Composition:** Steel framework, entirely moulded in cold-cure polyurethane.  
**Composizione:** Struttura della scocca in acciaio, interamente stampata in poliuretano schiumato a freddo.  
**Weight / Peso:** 9 kg  
**Required fabric / Tessuto occorrente:** 2,70 m. (h 1,40).

## Woody Lounge

**Composition:** Structure in rigid polyurethane with ultra soft expanded polyurethane foam.  
**Composizione:** Struttura portante in poliuretano rigido con imbottitura in poliuretano espanso ultra soft.  
**Weight / Peso:** from 16 to 19 kg  
**Required fabric / Tessuto occorrente:** 2,50 m. (h 1,40).

**Art**



01 02 03

**Bloom**



01 02 03 04

**Option 1**  
unique fabric

**Option 2**  
one fabric for the inner part and another for the outside

**Option 3**  
one fabric for the seat another for the backrest



**Woody**



01 02 03

**Option 1**  
unique fabric

**Option 2**  
one fabric for the inner part and another for the outside

**Option 3**  
two different mixed fabrics

**Option 4**  
one fabric for the seat another for the backrest

**Option 1**  
unique fabric

**Option 2**  
one fabric for the inner part and another for the outside

**Option 3**  
one fabric for the seat another for the backrest

**Diamond**



01 02 03

**Bloom Lounge**



01 02 03

**Option 1**  
unique fabric

**Option 2**  
one fabric for the inner part and another for the outside

**Option 3**  
one fabric for the seat another for the backrest



**Woody Lounge**



01 02 03

**Option 1**  
unique fabric

**Option 2**  
one fabric for the inner part and another for the outside

**Option 3**  
one fabric for the seat another for the backrest

**Option 1**  
unique fabric

**Option 2**  
one fabric for the inner part and another for the outside

**Option 3**  
one fabric for the seat another for the backrest

**Look & Look open**



01 02 03

**Olie**

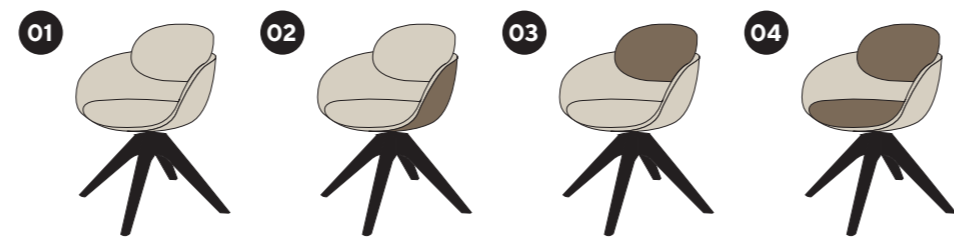

01 02 03 04

**Option 1**  
unique fabric

**Option 2**  
one fabric for the inner part and another for the outside

**Option 3**  
one fabric for the seat another for the backrest



**Option 1**  
unique fabric

**Option 2**  
one fabric for the inner part and another for the outside

**Option 3**  
two different mixed fabrics

**Option 4**  
one fabric for the structure and another for the cushions



**Kuma& Kuma open**



01 02

**Olie Lounge**

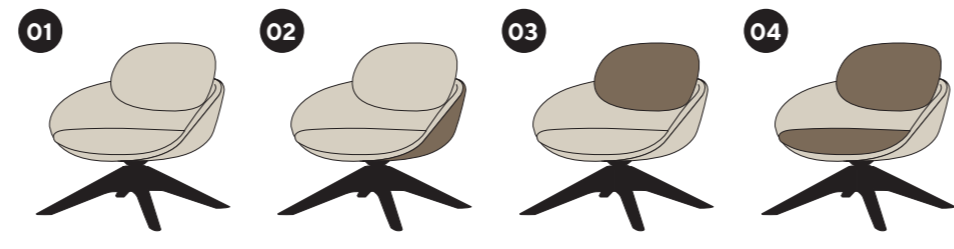

01 02 03 04

**Option 1**  
unique fabric

**Option 2**  
one fabric for the inner part and another for the outside



**Option 1**  
unique fabric

**Option 2**  
one fabric for the inner part and another for the outside

**Option 3**  
two different mixed fabrics

**Option 4**  
one fabric for the structure and another for the cushions



**Tera**

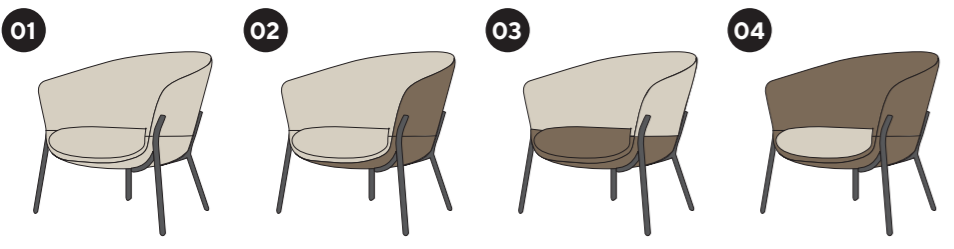

01 02 03 04

**Option 1**  
unique fabric

**Option 2**  
one fabric for the inner part and another for the outside

**Option 3**  
one fabric for the seat another for the backrest

**Option 4**  
two different mixed fabrics



**Curvy**



01 02 03

**Option 1**  
unique fabric

**Option 2**  
one fabric for the inner part and another for the outside

**Option 3**  
one fabric for the seat another for the backrest



**Option 1**  
unique fabric

**Option 2**  
one fabric for the inner part and another for the outside

**Option 3**  
one fabric for the seat another for the backrest



**Thea**



01 02 03

**Option 1**  
unique fabric

**Option 2**  
one fabric for the inner part and another for the outside

**Option 3**  
one fabric for the seat another for the backrest

**Dahlia**



01 02 03

**Option 1**  
unique fabric

**Option 2**  
one fabric for the inner part and another for the outside

**Option 3**  
one fabric for the seat another for the backrest

**Option 1**  
unique fabric

**Option 2**  
one fabric for the inner part and another for the outside

**Option 3**  
one fabric for the seat another for the backrest

# Poison

ARMCHAIRS

VOLUME 7.0

94

INNOVA



POLTRONE

## Bases



L17



L13



R1



R15



P2 (fissa/fixed)  
P10 (girevole/swivelling)



C1



N1



N1R

VOLUME 7.0

95

INNOVA

The Poison armchair exudes an aura of elegant simplicity and sophistication. A design that allows to play with different wooden or metal bases and with combinations contemporary fabrics.

La poltroncina Poison emana un'aura di elegante semplicità e sofisticatezza. Un design che permette di giocare con diverse basi in legno o metallo e con combinazioni di tessuti contemporanei.



# Noem

## Bases



L7



L26



L12



S5



C1



R1



P2 (fissa / fixed)  
P10 (girevole / swivelling)



N1 (no castors / no ruote)  
N1R (with castors / con ruote)

VOLUME 70

96

INNOVA



Simple and lively, what else? That is the life we want to. Just whistle and Noem is ready to kick, upon her tapered legs, to reach offices, hotels, domestic and contract environments.

Semplice e frizzante, come altro è la vita che vogliamo? Basta un fischio e Noem è pronta a sgambettare, su gambe sempre affusolate, verso uffici, alberghi, contesti domestici e contract.



VOLUME 70

97

INNOVA

FROM LEFT NOEM L17, NOEM L12 AND NOEM L7

# Kat

ARMCHAIRS

VOLUME 7.0

98

INNOVA



POLTRONE



VOLUME 7.0

99

INNOVA



Kat is a slight and sensitive little armchair. As its related sofa, its peculiarity is the thin structure, where the seat and the two small armrest wings lean on.

Kat è una poltroncina dall'aspetto esile e delicato. Come il divano della stessa famiglia, la sua particolarità è la struttura sottile, su cui appoggiano la seduta e le piccole ali dei braccioli.

**FAMILY PRODUCT**

## Bases



R13



L21



R7



D9



L31



S7



New look! It's Look Lounge. You know, you grow along with the time. What a satisfaction! It has happened also to this armchair, which is more and more comfortable, with a wider and deeper seat.

Nuovo look! È Look Lounge. Si sa, con il tempo ci si allarga un po'. Che soddisfazione! È successo anche a questa poltroncina, sempre più accogliente, con una seduta più ampia e profonda.

FAMILY PRODUCT

# Look

LOUNGE



LOOK LOUNGE L31

# Smoky

LOW

VOLUME 7.0

102

INNOVA

LOUNGE

LOUNGE

## Bases



L21



L25



L31



R13



R7/POUF SKY R4



S7

VOLUME 7.0

103

INNOVA



POUF SKY L27 AND SMOKY LOW L21

Armchair with soft and sinuous lines. different high of the back make it suitable for various location: the office of the "boss", meeting rooms and at home, why not?

Poltroncina dalle linee morbide e sinuose. La possibilità di avere più opzioni per l'altezza dello schienale la rende adatta ad ambienti diversi: per l'ufficio del "capo", per grandi sale riunioni e, perché no, per la casa.

FAMILY PRODUCT



BESPOKE

LOUNGE

# Bases

VOLUME 70



L21



L25



L31

104



R13



R7/POUFSKY R4



S7

INNOVA



FAMILY PRODUCT

LOUNGE

# Smoky

MEDIUM



SMOKY MEDIUM R13

# Smoky

HIGH

LOUNGE

VOLUME 7.0

106

INNOVA



SMOKY HIGH L25

LOUNGE

## Bases



L21



L31



L25



R13



R7/POUF SKY R4



S7

VOLUME 7.0

107

INNOVA

FAMILY PRODUCT



LOUNGE

BISY R13



VOLUME 70

108

BISY L21



INNOVA

Wooden or metal base with a solid, wide and ergonomic seat. Slope and padding of the back make Bisy inviting and comfortable.

Basamento in legno o in acciaio con una seduta compatta, ampia ed ergonomica. La leggera inclinazione e l'imbottitura sullo schienale rendono Bisy una poltroncina comoda e accogliente.

LOUNGE

# Bisy

VOLUME 70

109



INNOVA

BISY GL2

# Adam



VOLUME 7.0

110

INNOVA



LOUNGE

LOUNGE

ADAM L21



VOLUME 7.0

111

ADAM GL2+  
POUF ADAM



An elegant armchair that visually suggests an idea of comfort, thanks to the wide and wrapping backrest and to the high cushion of the seat.

Una poltrona raffinata che suggerisce anche visivamente un'idea di comodità, grazie all'ampio schienale avvolgente e al cuscino alto del sedile.

**FAMILY PRODUCT**



INNOVA

LOUNGE



VOLUME 70

112



INNOVA

It happened. Adam has grown up, and here is Adam High with an even higher and more comfortable backrest. He knows how to define a unique, private and pleasant space.

È successo. Adam si è fatto grande, ed ecco Adam High con uno schienale ancora più alto e comodo. Sa delimitare uno spazio unico, riservato e piacevole.

FAMILY PRODUCT

LOUNGE

# Adam

HIGH



VOLUME 70

113

INNOVA

ADAM HIGH AND POUF ADAM

# Bands

LOUNGE

LOUNGE

LOUNGE

ROCKING LOUNGE /  
DONDOLO LOUNGE

ARMCHAIR LOUNGE /  
POLTRONA LOUNGE

The particular seat of Bands, in its high or low version, can be combined also to the rocking base in solid beech wood.

La caratteristica seduta di Bands, in versione alta o bassa, si può abbinare anche alla base a dondolo in faggio massiccio.

**FAMILY PRODUCT**

VOLUME 7.0

114

INNOVA

VOLUME 7.0

115

INNOVA





ARMCHAIR BERGÈRE /  
POLTRONA BERGÈRE



ROCKING BERGÈRE /  
DONDOLO LOUNGE



# Bands

BERGÈRE

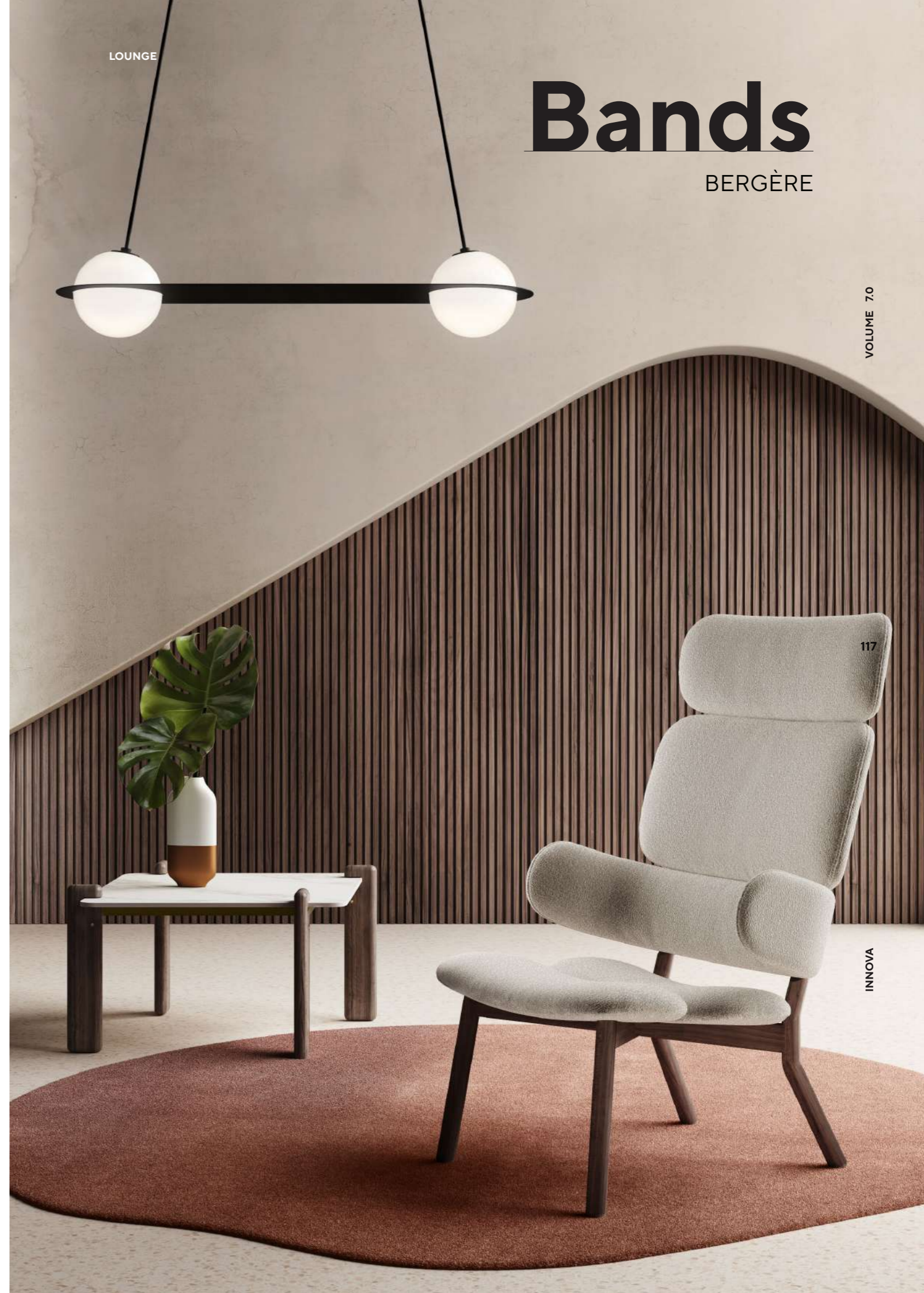

Bergère reinterpretation of the namesake chair, the armchair bands has a great padding with different levels that makes it comfortable.

Reinterpretazione in chiave bergère dell'omonima sedia, la poltrona bands ha un'imbottitura a quote differenziate, che la rende comoda e confortevole.

FAMILY PRODUCT

# Berg

LOW

VOLUME 7.0

118

INNOVA

LOUNGE

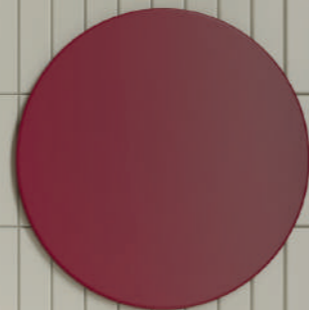

FROM LEFT BERG LOW L40 AND BERG LOW P 20 WITH PADDED OPTION

LOUNGE

## Bases



L21/POUF L27



L40



R13



R7/POUF R8



R11



P20/POUF P17

VOLUME 7.0

119

INNOVA

A soft and linear armchair, as elegant and rigorous in its aesthetics as its construction, entrusted to a technology that guarantees notable comfort even in essential forms.

Una poltrona morbida e lineare, elegante e rigorosa nell'estetica quanto nella modalità costruttiva affidata a una tecnologia che garantisce comfort notevole anche a forme essenziali.

FAMILY PRODUCT



## Bases



L 21/ POUF L27  
\* OPTION WAVE SYSTEM



L40



R13/ POUF R14  
\* OPTION WAVE SYSTEM



R7/ POUF R8  
\* OPTION WAVE SYSTEM



R11  
\* OPTION WAVE SYSTEM



P20 / POUF P17

VOLUME 70

120

INNOVA



Berg high is a large chair: it draws attention. It also guarantees comfort, from its reclining backrest to its soft headrest, which can be personalised in contrasting fabrics.

Berg high vanta una mole notevole: richiama l'attenzione. E garantisce comodità, dallo schienale reclinabile al morbido poggiatesta, personalizzabile con tessuto a contrasto.

FAMILY PRODUCT

# Berg

HIGH



VOLUME 70

121

INNOVA

BERG HIGH R13

# Not just standard

BE SPOKE

BE SPOKE

VOLUME 7.0



VOLUME 7.0

122



123

INNOVA

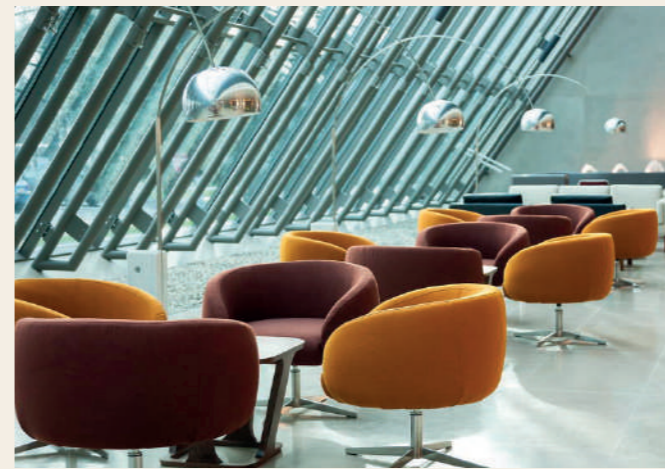

INNOVA

# Reference



Nobu

Hotel Garberhof

VOLUME 70

124

INNOVA

## Poison

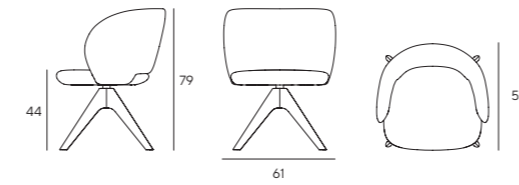

## Kat

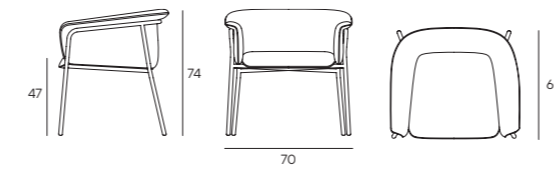

## Smoky Low

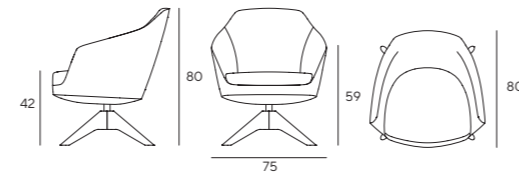

## Smoky High

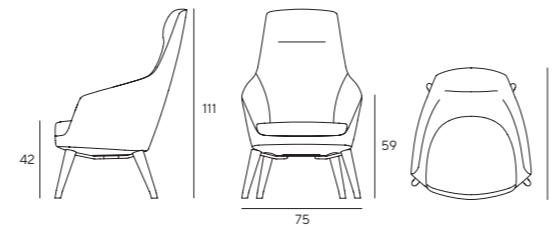

## Adam

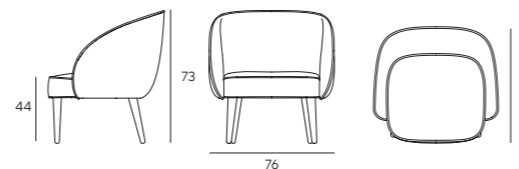

## Bands Lounge

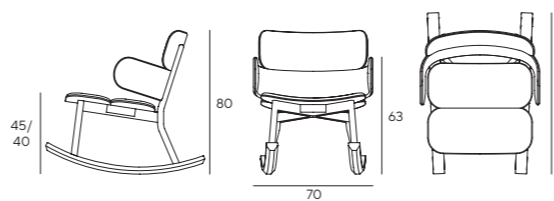

## Berg Low

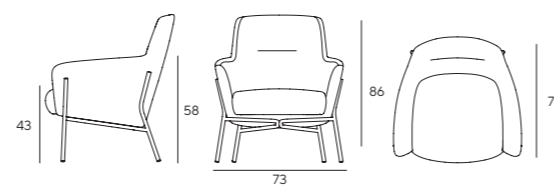

## Noem

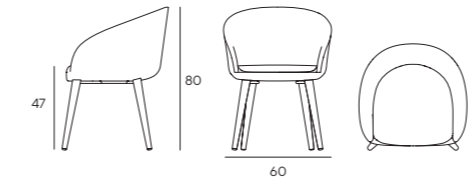

## Look Lounge

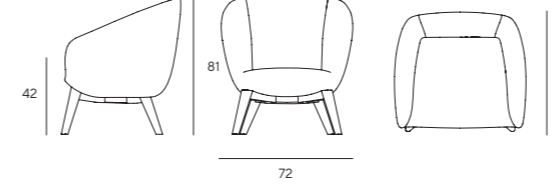

## Smoky Medium

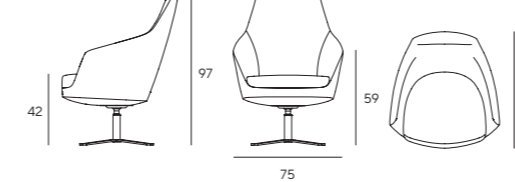

## Bisy

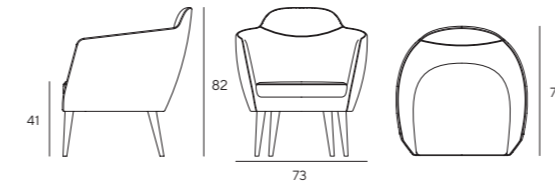

## Adam High

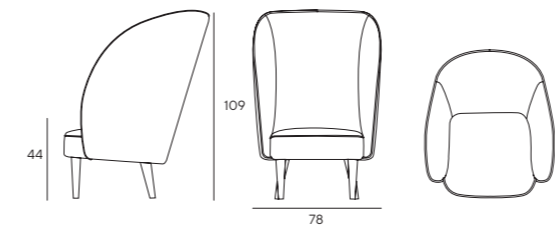

## Bands Bergère

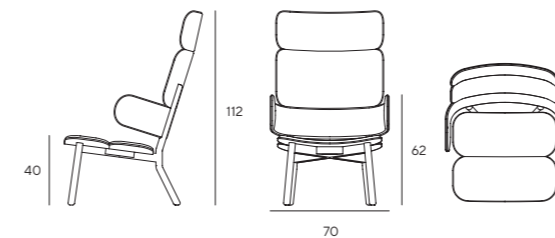

## Berg High

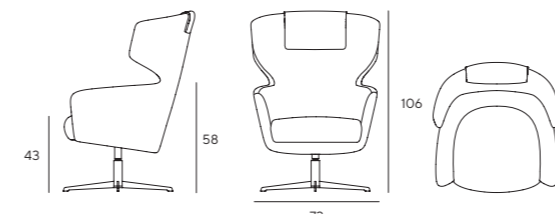

VOLUME 70

125

INNOVA

## Poison

R-L

**Composition:** Steel framework, entirely moulded in cold-cure polyurethane.  
**Composizione:** Struttura della scocca in acciaio, interamente stampata in poliuretano schiumato a freddo.  
**Weight / Peso:** from 9 to 15 kg  
**Required fabric / Tessuto occorrente:** 1,50 m. (h 1,40).

## Kat

R

**Composition:** Metal structure, backrest and seat in curved plywood upholstered with expanded polyurethane foam.  
**Composizione:** Struttura della base in metallo, schienale e seduta in multistrato e curvato, imbottito con poliuretano espanso.  
**Weight / Peso:** 18 kg  
**Required fabric / Tessuto occorrente:** 2,50 m. (h 1,40).

## Smoky Low

C

**Composition:** Steel framework, entirely moulded in cold-cure polyurethane.  
**Composizione:** Struttura della scocca in acciaio, interamente stampata in poliuretano schiumato a freddo.  
**Weight / Peso:** from 18 to 30 kg  
**Required fabric / Tessuto occorrente:** 2,80 m. (h 1,40).

## Smoky High

C

**Composition:** Steel framework, entirely moulded in cold-cure polyurethane.  
**Composizione:** Struttura della scocca in acciaio, interamente stampata in poliuretano schiumato a freddo.  
**Weight / Peso:** from 18 to 30 kg  
**Required fabric / Tessuto occorrente:** 3,00 m. (h 1,40).

## Adam

R-L

**Composition:** The structure of the body is in solid wood and curved plywood, upholstered with expanded polyurethane foam and dacron.  
**Composizione:** Struttura della scocca in legno massello e composito curvato, imbottitura in poliuretano espanso e dacron.  
**Weight / Peso:** armchair from 16 to 21 kg  
**Required fabric / Tessuto occorrente:** complete armchair 2,50 m. (h 1,40) only piping 2,50 m. (h 1,40)

## Bands Lounge

L-C

**Composition:** Solid beech wood structure, backrest and seat in curved plywood with expanded polyurethane foam.  
**Composizione:** Struttura della base in massello di faggio, schienale e seduta in multistrato curvato, imbottiti con poliuretano espanso a quote differenziate.  
**Weight / Peso:** 16 kg  
**Required fabric / Tessuto occorrente:** 3,00 mt. (h 1,40).

## Berg Low

R-L

**Composition:** Structure with metal inner frame entirely moulded in cold-cure polyurethane. Seat cushion with a system **SPRING PACK**, for higher comfort.  
**Composizione:** Struttura in metallo interamente stampata in poliuretano schiumato a freddo. Sedile con sistema **SPRING PACK**, per una maggiore confortevolezza.  
**Weight / Peso:** armchair from 14 to 25 kg  
**Required fabric / Tessuto occorrente:** complete armchair 3,20 m. (h 1,40) only headrest 0,50 m. (h 1,40).

## Noem

R-L

**Composition:** Steel framework, entirely moulded in cold-cure polyurethane.  
**Composizione:** Struttura della scocca in acciaio, interamente stampata in poliuretano schiumato a freddo.  
**Weight / Peso:** from 12 to 16 kg  
**Required fabric / Tessuto occorrente:** 1,80 m. (h 1,40).

## Look Lounge

C

**Composition:** Steel framework, entirely moulded in cold-cure polyurethane.  
**Composizione:** Struttura della scocca in acciaio, interamente stampata in poliuretano schiumato a freddo.  
**Weight / Peso:** from 15 to 26 kg  
**Required fabric / Tessuto occorrente:** 2,50 m. (h 1,40).

## Smoky Medium

C

**Composition:** Steel framework, entirely moulded in cold-cure polyurethane.  
**Composizione:** Struttura della scocca in acciaio, interamente stampata in poliuretano schiumato a freddo.  
**Weight / Peso:** from 18 to 30 kg  
**Required fabric / Tessuto occorrente:** 2,90 m. (h 1,40).

## Bisy

C

**Composition:** The structure of the body is in solid wood and curved plywood, upholstered with expanded polyurethane foam and dacron.  
**Composizione:** Struttura della scocca in legno massello e composito curvato, imbottitura in poliuretano espanso e dacron.  
**Weight / Peso:** from 18 to 25 kg  
**Required fabric / Tessuto occorrente:** 3,00 m. (h 1,40).

## Adam High

R-L

**Composition:** The structure of the body is in solid wood and curved plywood, upholstered with expanded polyurethane foam and dacron.  
**Composizione:** Struttura della scocca in legno massello e composito curvato, imbottitura in poliuretano espanso e dacron.  
**Weight / Peso:** 26,5 kg  
**Required fabric / Tessuto occorrente:** complete armchair 4,00 m. (h 1,40) only piping 2,50 m. (h 1,40).

## Bands Bergère

L-C-B

**Composition:** Solid beech wood structure, backrest and seat in curved plywood with expanded polyurethane foam.  
**Composizione:** Struttura della base in massello di faggio, schienale e seduta in multistrato curvato, imbottiti con poliuretano espanso a quote differenziate.  
**Weight / Peso:** 20 kg  
**Required fabric / Tessuto occorrente:** 3,50 m. (h 1,40).

## Berg High

L-C-B

**Composition:** Structure with metal inner frame entirely moulded in cold-cure polyurethane. Seat cushion with a system **SPRING PACK**, for higher comfort.  
**Composizione:** Struttura in metallo interamente stampata in poliuretano schiumato a freddo. Sedile con sistema **SPRING PACK**, per una maggiore confortevolezza.  
**Weight / Peso:** armchair from 19 to 25 kg  
**Required fabric / Tessuto occorrente:** complete armchair 3,20 m. (h 1,40) only headrest 0,50 m. (h 1,40).

VOLUME 70

126

INNOVA



**Option 1**  
unique fabric

**Option 2**  
one fabric for the outside backrest and another for the rest

**Option 3**  
one fabric for the seat another for the backrest

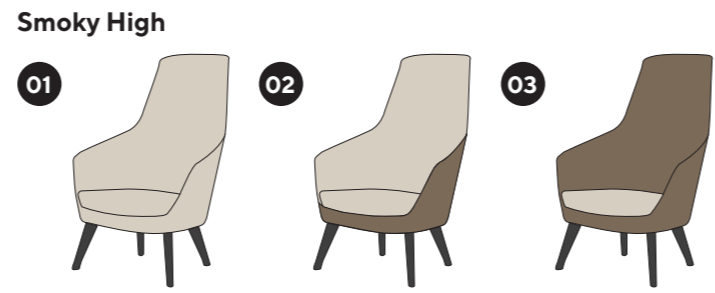

**Option 1**  
unique fabric

**Option 2**  
one fabric for the inner part and another for the outside

**Option 3**  
one fabric for the seat another for the backrest

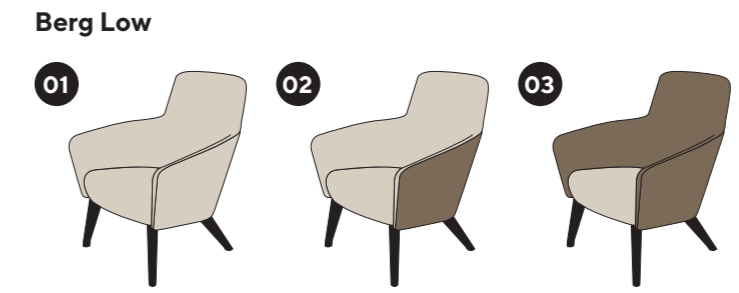

**Option 1**  
unique fabric

**Option 2**  
one fabric for the inner part and another for the outside

**Option 3**  
one fabric for the seat another for the backrest



**Option 1**  
unique fabric

**Option 2**  
one fabric for the outside backrest and another for the rest

**Option 3**  
one fabric for the seat another for the backrest

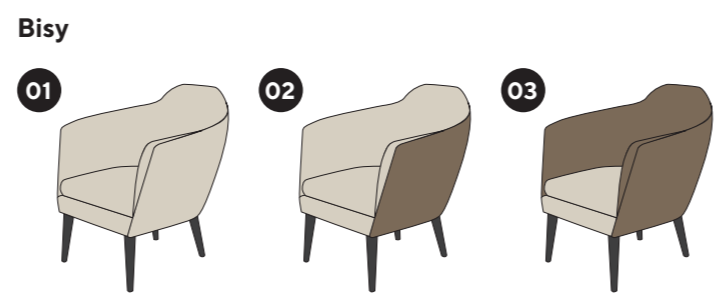

**Option 1**  
unique fabric

**Option 2**  
one fabric for the outside backrest and another for the rest

**Option 3**  
one fabric for the seat another for the backrest



**Option 1**  
unique fabric

**Option 2**  
one fabric for the outside backrest and another for the rest

**Option 3**  
one fabric for the seat another for the backrest

**Option 4**  
two different mixed fabrics

**NB: headrest it's a optional**



**Option 1**  
unique fabric

**Option 2**  
one fabric for the outside backrest and another for the rest

**Option 3**  
one fabric for the seat another for the backrest

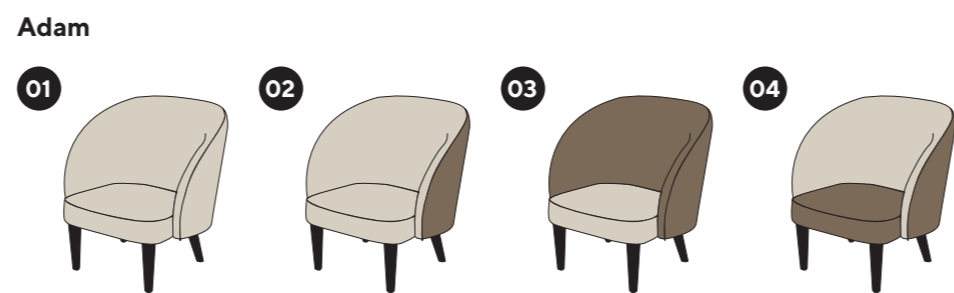

**Option 1**  
unique fabric

**Option 2**  
one fabric for the outside backrest and another for the rest

**Option 3**  
one fabric for the seat another for the backrest

**Option 4**  
two different mixed fabrics

**NB: piping will be the same colour as the outside fabric**

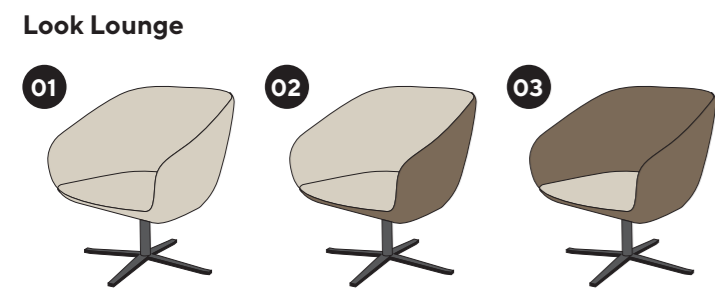

**Option 1**  
unique fabric

**Option 2**  
one fabric for the inner part and another for the outside

**Option 3**  
one fabric for the seat another for the backrest

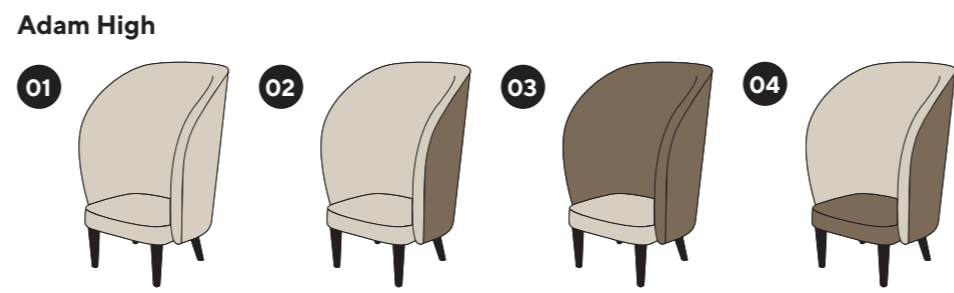

**Option 1**  
unique fabric

**Option 2**  
one fabric for the outside backrest and another for the rest

**Option 3**  
one fabric for the seat another for the backrest

**Option 4**  
two different mixed fabrics

**NB: piping will be the same colour as the outside fabric**

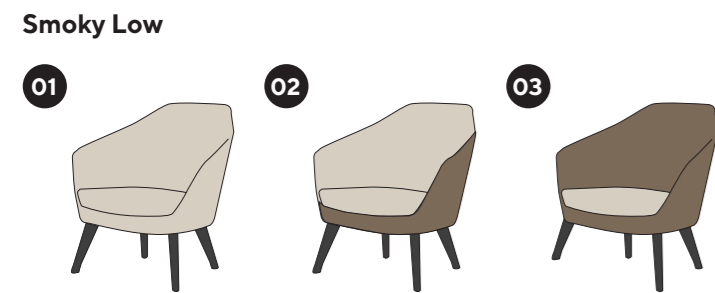

**Option 1**  
unique fabric

**Option 2**  
one fabric for the inner part and another for the outside

**Option 3**  
one fabric for the seat another for the backrest

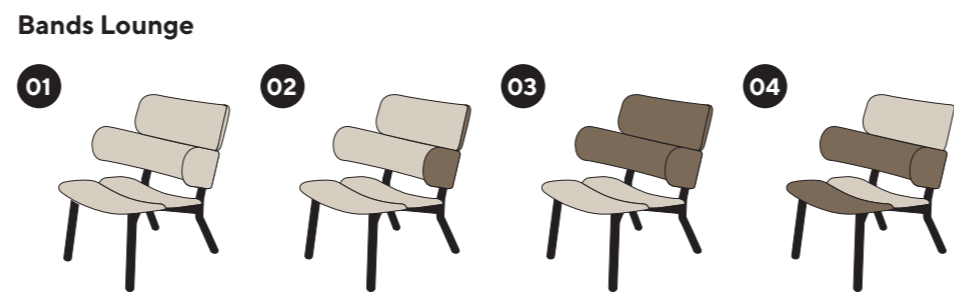

**Option 1**  
unique fabric

**Option 2**  
one fabric for the outside backrest and another for the rest

**Option 3**  
one fabric for the seat another for the backrest

**Option 4**  
two different mixed fabrics



**Option 1**  
unique fabric

**Option 2**  
one fabric for the inner part and another for the outside

**Option 3**  
one fabric for the seat another for the backrest

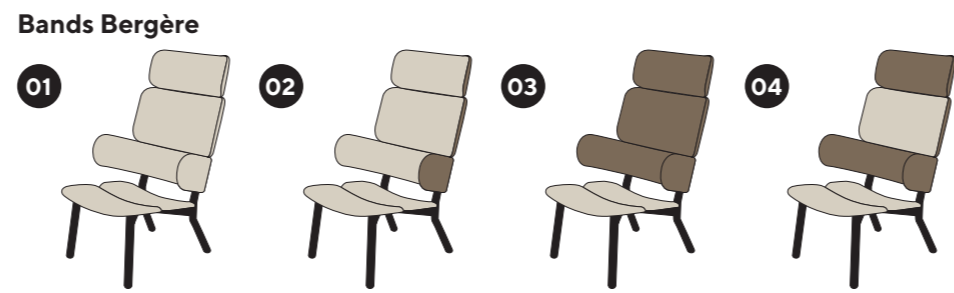

**Option 1**  
unique fabric

**Option 2**  
one fabric for the outside backrest and another for the rest

**Option 3**  
one fabric for the seat another for the backrest

**Option 4**  
two different mixed fabrics

# Circus

LOW

LOUNGE

VOLUME 7.0

130

INNOVA



LOUNGE



VOLUME 7.0

131

INNOVA



Just like the circus, the metal structure is simple. The folds of the fabric are inserted above, laid out in a harmonious way to welcome and embrace.

Come al circo, la struttura in metallo è semplice. Sopra si inseriscono le volte del tessuto, tracciate in modo armonioso per accogliere e abbracciare. Una promessa di morbidezza.

**FAMILY PRODUCT**



The stature of Circus high is a promise maintained, not only in its softness but also its confidentiality, with a class that is almost regal.

La stazza di Circus high è una promessa mantenuta, non solo di morbidezza ma pure di riservatezza, in una modalità di classe, quasi regale.

**FAMILY PRODUCT**

# Circus

HIGH



# Eleven

LOUNGE

VOLUME 7.0

134

INNOVA



LOUNGE



VOLUME 7.0

135

INNOVA



A turned wood base, balanced and elegant, with a strong character. What it supports is a seductive seat with its numerous draperies of fabric, like promised caresses. A promise of softness.

Un basamento in legno tornito, equilibrato ed elegante, dal forte carattere. In appoggio, una seduta seducente con i suoi numerosi drappaggi di tessuto, quasi carezze promesse. Una promessa di morbidezza.

**FAMILY PRODUCT**

## Bases



L21



R13



R7



GM1

Kyo should have been a barstool with a wide seat.  
But where is the ambition? And the initiative? A  
crown encloses herself, since she wants more. And  
she became an armchair. Royal.

Kyo poteva essere uno sgabello dall'ampia seduta.  
Ma dove mettiamo l'ambizione?  
E l'intraprendenza? D'una corona si cinse perché  
voleva di più. E divenne poltrona. Regale.

FAMILY PRODUCT

# Kyo



KYO GM1

# Arsenale

LC1

LOUNGE

VOLUME 7.0

138

INNOVA



LOUNGE



VOLUME 7.0

139

INNOVA



Arsenale has soft lines and a large and enveloping back. The details of wooden legs interlaced with the seat give a strong personality to the item.

Arsenale è caratterizzata da linee morbide e da un grande e avvolgente schienale. La particolarità del gioco d'incastro delle gambe con la seduta dà una forte personalità al prodotto.

**FAMILY PRODUCT**

LOUNGE



VOLUME 70

140



INNOVA

A sophisticated design and a discrete and thin structure of the backrest and armrests that encompasses the seat, encouraging conviviality and relaxation.

Un design raffinato e una struttura sottile e discreta che si fonde perfettamente con il grande cuscino di seduta morbido e accogliente.

FAMILY PRODUCT

LOUNGE

# Arsenale

GL1

VOLUME 70

141



INNOVA

# Arsenale

BERGÈRE

LOUNGE

VOLUME 7.0

142

INNOVA



LOUNGE



VOLUME 7.0

143

INNOVA



The iconic Arsenale turns into an even more contemporary look. Reserved and enveloping, its new shape embraces comfort with a gently elongated backrest that supports the spine with warmth and hospitality.

L'iconica Arsenale si trasforma in un look ancor più contemporaneo. Riservata ed avvolgente, la sua nuova forma abbraccia il comfort, con uno schienale che si allunga dolcemente per sostenere la schiena con calore e accoglienza.

**FAMILY PRODUCT**

Bases



R13  
Pad option  
Versione morbida



L21



R7  
Pad option  
Versione morbida

VOLUME 70

144



INNOVA

Otta lounge is absolute softness. A glance is enough to follow the warm invitation to sit down, whispered by the captivating contrast of fabrics and colours between the cushion and the shell.

Otta lounge è morbidezza assoluta. Basta uno sguardo per seguire il caldo invito ad accomodarsi, sussurrato dall'accattivante contrasto di tessuti e colori tra cuscino e scocca.

Otta



VOLUME 70

145

INNOVA

# Nobu

LOUNGE

VOLUME 7.0

146

INNOVA



LOUNGE



VOLUME 7.0

147

INNOVA



Nobu is a majestic display of fabric. It will never go unnoticed. How to ignore its soft and sinuous forms resting on its bold base? Lovely contrast. Truly unique!

Nobu è maestosa esibizione di tessuto. Di certo non passerà mai inosservata. Come ignorare le sue forme morbide e sinuose adagate sul basamento grintoso? Bel contrasto. Unica!

**FAMILY PRODUCT**

LOUNGE

MELLA BM13



VOLUME 70

MELLA GM  
+ TABLES



148



INNOVA

Mella is inspired by the soft and sinuous shapes of sweets and sugared almonds. The contained and rounded dimensions of the product make the collection adaptable to any space and context.

Mella si ispira alle forme morbide e sinuose di caramelle e confetti. Le dimensioni contenute e tonde del prodotto rendono la collezione adattabile ad ogni spazio e contesto.

FAMILY PRODUCT

LOUNGE

# Mella

VOLUME 70

149



INNOVA

# Lucy & Justin

LOUNGE

VOLUME 7.0

150

INNOVA



LOUNGE

JUSTIN



LUCY



VOLUME 7.0

151



Lucy and Justin are born as twin sisters, yet different. One is soft, elegant, and charming, while the other is simpler, discreet but still distinctive.

Lucy e Justin nascono come due gemelle, ma diverse. Una è morbida, elegante e affascinante, mentre l'altra è più semplice, discreta ma comunque distintiva.

LOUNGE



VOLUME 70

152



INNOVA

Merge is combination and simultaneity, highlighted through its distinctive base design, which evokes a sense of harmony and connection. Soft shapes and traditional materials juxtaposed with unexpected finishing and colours.

Merge è unione e simultaneità, evidenziata attraverso il suo design distintivo della base, che evoca senso di armonia e connessione. Forme morbide e materiali tradizionali messi a contrasto con finiture e colori inattesi.

FAMILY PRODUCT

LOUNGE



# Merge

VOLUME 70

153

INNOVA

MERGE POUF AND MERGE ARMCHAIR

# Crabby

VOLUME 7.0

154

INNOVA



LOUNGE

LOUNGE



VOLUME 7.0

155

INNOVA



There are shapes that fill us with joy, evoking sweet memories and dreams that make us smile. Crabby is inspired by a little crab dancing among the waves. It's a tribute to the love for the sea, to the authentic and pure beauty that surrounds us. A special product, among the first one in the Innova collection, with a completely removable cover and eco-friendly.

Ci sono forme che ci riempiono di gioia, evocando dolci ricordi e sogni che ci fanno sorridere. Crabby si ispira a un piccolo granchietto che danza tra le onde. È un omaggio all'amore per il mare, alla bellezza autentica e pura che ci circonda. Un prodotto speciale, tra i primi della linea Innova completamente sfoderabile ed eco-sostenibile.

# Reference



Arsenale

Lake Lodges Resort

## Circus Low

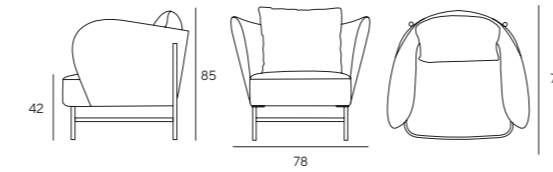

## Eleven

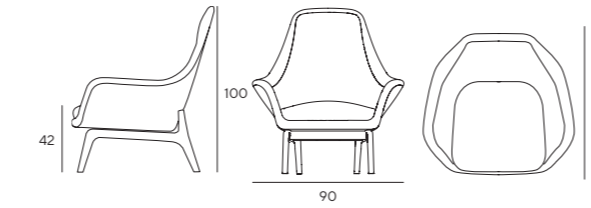

## Arsenale

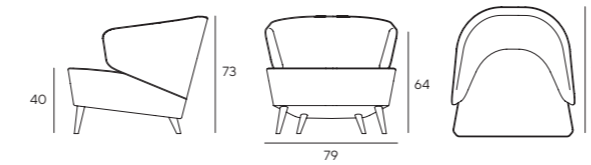

## Nobu

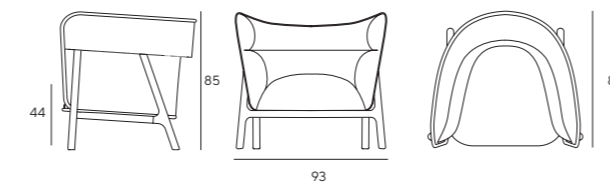

## Mella

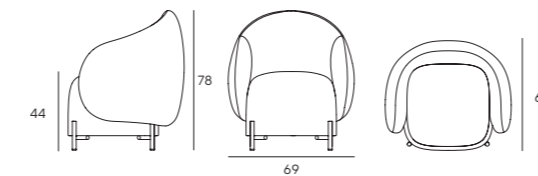

## Merge

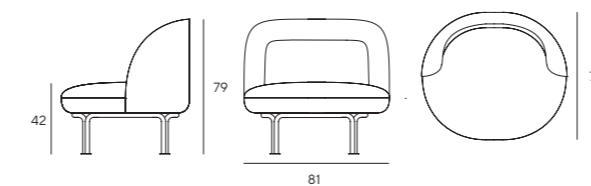

## Circus High

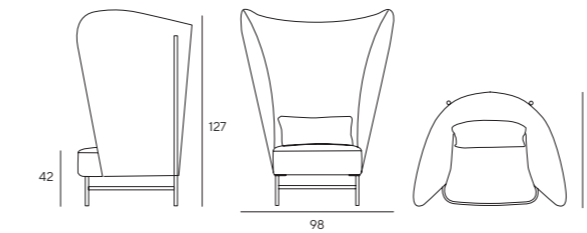

## Kyo

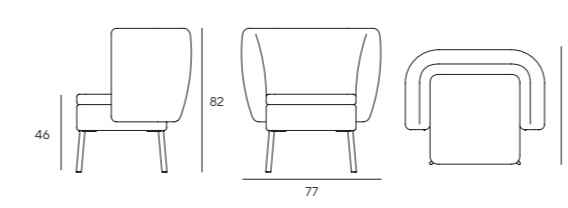

## Arsenale Bergère

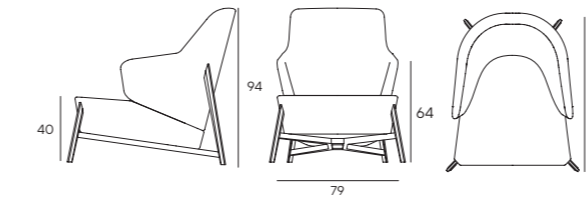

## Otta

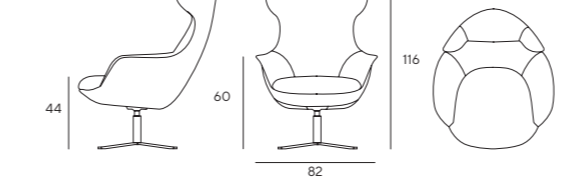

## Lucy & Justin

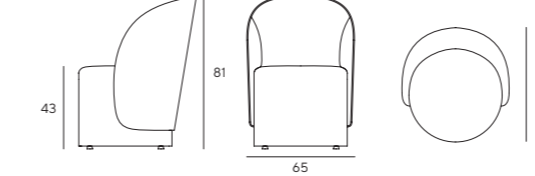

## Crabby

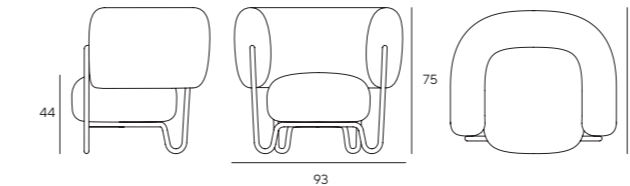

## Circus Low

L-C

**Composition:** The structure of the body is in solid wood and curved plywood, upholstered with expanded polyurethane foam and dacron.  
**Composizione:** Struttura della scocca in legno massello e composito curvato, imbottitura in poliuretano espanso e dacron.  
**Weight / Peso:** 24 kg  
**Required fabric / Tessuto occorrente:** 4,50 m. (h 1,40).

## Eleven

L

**Composition:** Steel framework, entirely moulded in cold-cure polyurethane.  
**Composizione:** Struttura della scocca in acciaio, interamente stampata in poliuretano schiumato a freddo.  
**Weight / Peso:** 20 kg  
**Required fabric / Tessuto occorrente:** 3,30 m. (h 1,40).

## Arsenale

L-C

**Composition:** The structure of the body is in solid wood and curved plywood, upholstered with expanded polyurethane foam and dacron.  
**Composizione:** Struttura della scocca in legno massello e composito curvato, imbottitura in poliuretano espanso e dacron.  
**Weight / Peso:** 22 kg  
**Required fabric / Tessuto occorrente:** 2,70 m. (h 1,40).

## Nobu

L-C-B

**Composition:** The structure of the body is in solid wood and curved plywood, upholstered with expanded polyurethane foam and dacron.  
**Composizione:** Struttura della scocca in legno massello e composito curvato, imbottitura in poliuretano espanso e dacron.  
**Weight / Peso:** 27 kg  
**Required fabric / Tessuto occorrente:** 5,00 m. (h 1,40), only piping 3,00 m. (h 1,40)

## Mella

L

**Composition:** The structure of the body is in solid wood and curved plywood, upholstered with expanded polyurethane foam and dacron. Metal varnished legs.  
**Composizione:** Struttura della scocca in legno massello e composito curvato, imbottitura in poliuretano espanso e dacron. Gambe in metallo.  
**Weight / Peso:** 18 kg, optional table 2 kg  
**Required fabric / Tessuto occorrente:** 3,00 m. (h 1,40)

## Merge

L-C

**Composition:** The structure of the body is in solid wood and curved plywood, upholstered with expanded polyurethane foam and dacron. Metal varnished base.  
**Composizione:** Struttura della scocca in legno massello e composito curvato, imbottitura in poliuretano espanso a quote differenziate e dacron. Basamento in metallo verniciato.  
**Weight / Peso:** 23 kg  
**Required fabric / Tessuto occorrente:** 3,00 m. (h 1,40).

## Circus High

L-C

**Composition:** The structure of the body is in solid wood and curved plywood, upholstered with expanded polyurethane foam and dacron.  
**Composizione:** Struttura della scocca in legno massello e composito curvato, imbottitura in poliuretano espanso e dacron.  
**Weight / Peso:** 35 kg  
**Required fabric / Tessuto occorrente:** 5,00 m. (h 1,40)

## Kyo

L-C

**Composition:** The structure of the body is in solid wood and curved plywood, upholstered with expanded polyurethane foam and dacron.  
**Composizione:** Struttura della scocca in legno massello e composito curvato, imbottitura in poliuretano espanso e dacron.  
**Weight / Peso:** from 21 to 25 kg  
**Required fabric / Tessuto occorrente:** 3,00 m. (h 1,40).

## Arsenale Bergère

L-C

**Composition:** The structure of the body is in solid wood and curved plywood, upholstered with expanded polyurethane foam and dacron.  
**Composizione:** Struttura della scocca in legno massello e composito curvato, imbottitura in poliuretano espanso e dacron.  
**Weight / Peso:** 22 kg  
**Required fabric / Tessuto occorrente:** 2,70 m. (h 1,40).

## Otta

L

**Composition:** Supporting structure in rigid polyurethane with ultra soft expanded polyurethane foam.  
**Composizione:** Struttura portante in poliuretano rigido con imbottitura in poliuretano espanso ultra soft.  
**Weight / Peso:** 30 kg  
**Required fabric / Tessuto occorrente:** 3,50 m. (h 1,40).

## Lucy & Justin

R

**Composition:** The structure of the body is in solid wood and curved plywood, upholstered with expanded polyurethane foam and dacron.  
**Composizione:** Struttura della scocca in legno massello e composito curvato, imbottitura in poliuretano espanso e dacron.  
**Weight / Peso:** 13 kg  
**Required fabric / Tessuto occorrente:** Lucy 2,50 m. (h 1,40), Lucy piping 2,10 m. (h 1,40), Justin 2,75 m. (h 1,40), Justin piping 2,75 m. (h 1,40).

## Crabby

R-L-C-B

**Composition:** Steel framework with expanded polyurethane foam and dacron. Removable cover and disassemblable.  
**Composizione:** Struttura della scocca in acciaio con imbottitura in poliuretano espanso e dacron. Sfoderabile e disassemblabile.  
**Weight / Peso:** 19 kg  
**Required fabric / Tessuto occorrente:** 3,50 m. (h 1,40).

Circus Low

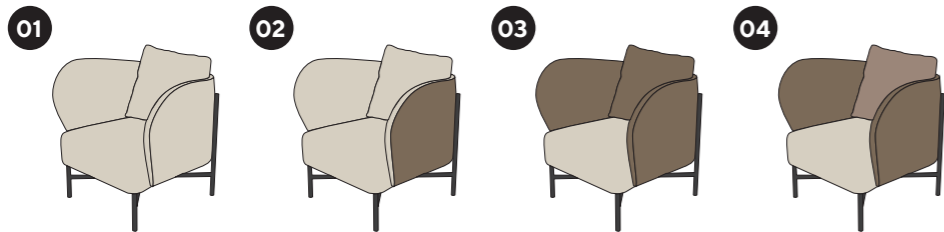

- Option 1**  
unique fabric
- Option 2**  
one fabric for the inner part and another for the outside
- Option 3**  
one fabric for the seat another for the backrest
- Option 4**  
two different mixed fabrics



Nobu



- Option 1**  
unique fabric
  - Option 2**  
one fabric for the inner part and another for the outside
  - Option 3**  
one fabric for the seat another for the backrest
- NB: piping will be the same colour as the outside fabric**

VOLUME 7.0

Circus High

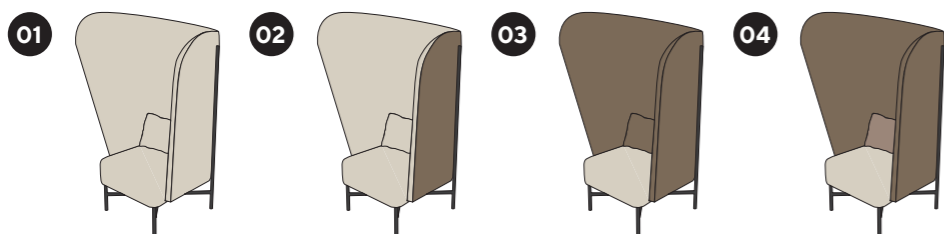

- Option 1**  
unique fabric
- Option 2**  
one fabric for the inner part and another for the outside
- Option 3**  
one fabric for the seat another for the backrest
- Option 4**  
two different mixed fabrics



Otta



- Option 1**  
unique fabric
- Option 2**  
one fabric for the inner part and another for the outside
- Option 3**  
one fabric for the seat another for the backrest

VOLUME 7.0

Eleven



- Option 1**  
unique fabric
- Option 2**  
one fabric for the inner part and another for the outside
- Option 3**  
one fabric for the seat another for the backrest



Mella

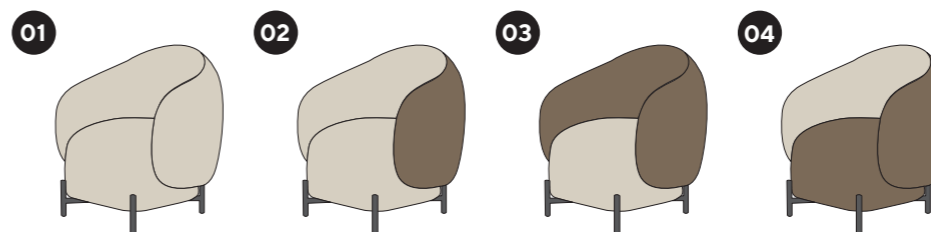

- Option 1**  
unique fabric
  - Option 2**  
one fabric for the outside backrest and another for the rest
  - Option 3**  
one fabric for the seat another for the backrest
  - Option 4**  
two different mixed fabrics
- NB: piping will be the same colour as the outside fabric**



159

Kyo

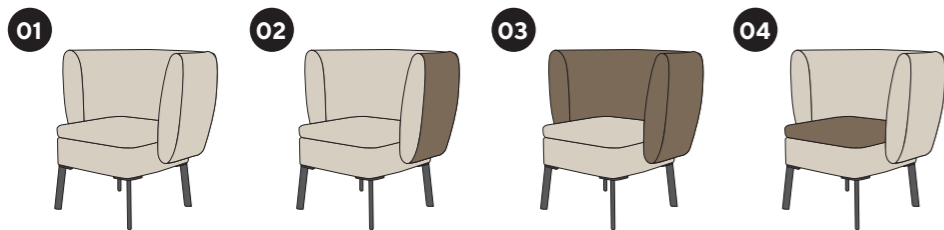

- Option 1**  
unique fabric
- Option 2**  
one fabric for the outside backrest and another for the rest
- Option 3**  
one fabric for the seat another for the backrest
- Option 4**  
two different mixed fabrics



Lucy

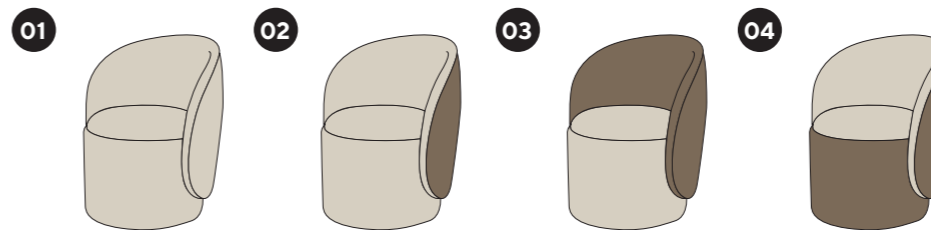

- Option 1**  
unique fabric
  - Option 2**  
one fabric for the outside backrest and another for the rest
  - Option 3**  
one fabric for the seat another for the backrest
  - Option 4**  
two different mixed fabrics
- NB: piping will be the same colour as the outside fabric**



160

Arsenale

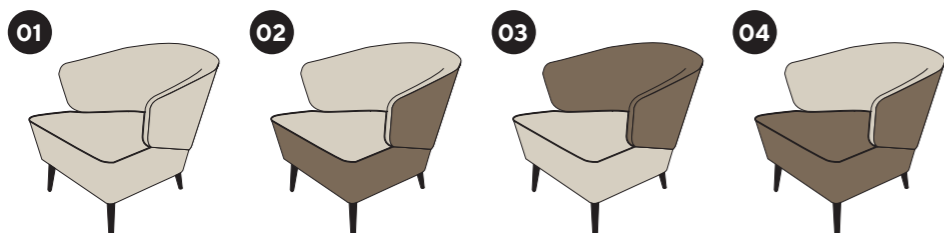

- Option 1**  
unique fabric
- Option 2**  
one fabric for the outside backrest and another for the rest
- Option 3**  
one fabric for the seat another for the backrest
- Option 4**  
two different mixed fabrics



Merge

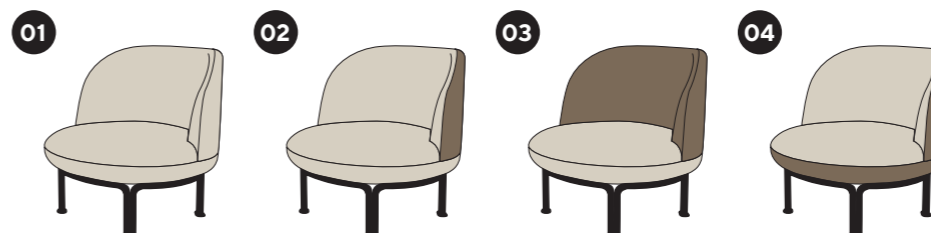

- Option 1**  
unique fabric
- Option 2**  
one fabric for the outside backrest and another for the rest
- Option 3**  
one fabric for the seat another for the backrest
- Option 4**  
two different mixed fabrics



INNOVA

Arsenale Bergère

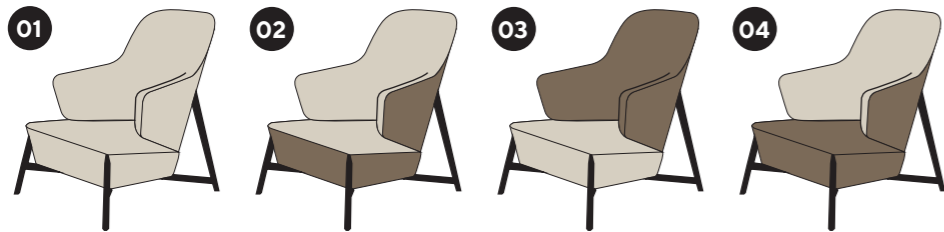

- Option 1**  
unique fabric
- Option 2**  
one fabric for the outside backrest and another for the rest
- Option 3**  
one fabric for the seat another for the backrest
- Option 4**  
two different mixed fabrics



Crabby

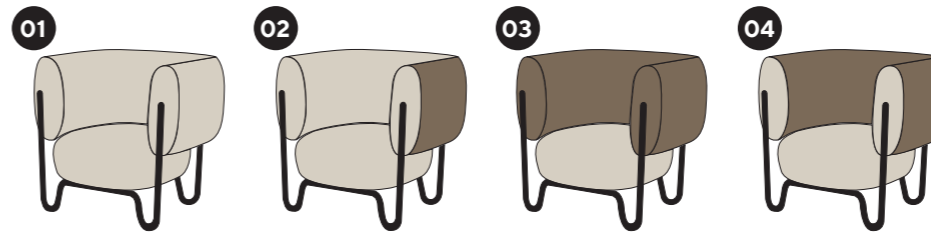

- Option 1**  
unique fabric
- Option 2**  
one fabric for the outside backrest and another for the rest
- Option 3**  
one fabric for the seat another for the backrest
- Option 4**  
two different mixed fabrics

INNOVA

Sofas and small sofas often furnish contract reception environments, such as waiting rooms, hotel lobbies, stations and airports, cinema and theatre foyers. In similar spaces people are looking for a comfortable seat, which shortens the distance between public and domestic space. Innova offers different solutions, with sofas that reflect the aesthetics of our chairs and armchairs with which they can be combined, and with different proposals, to be matched in contrast, for example a sofa with a high backrest and armrests, true walls of comfort, reflecting the most current trends.

Divani e divanetti arredano spesso gli ambienti del contract dedicati all'attesa come sale d'aspetto, hall di alberghi, stazioni e aeroporti, foyer di cinema e teatri. Qui, le persone cercano una seduta comoda e confortevole, che accorci la distanza tra ambiente pubblico e spazio domestico. Innova propone diverse soluzioni, con divani che riprendono l'estetica delle sedie e delle poltrone con cui si combinano, e pure con proposte diverse, da abbinare a contrasto, come il divano con schienale e braccioli alti, vere pareti di comfort, in linea con le tendenze più attuali.

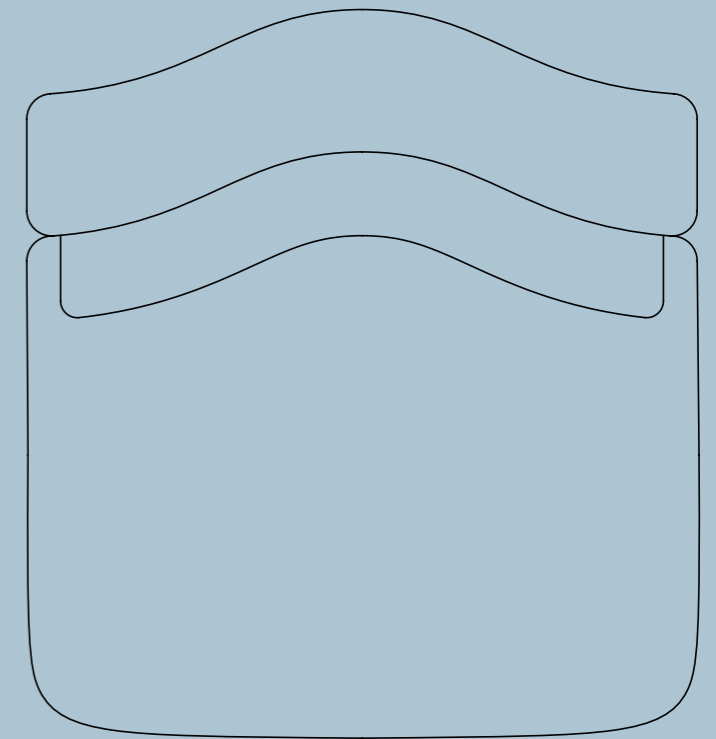
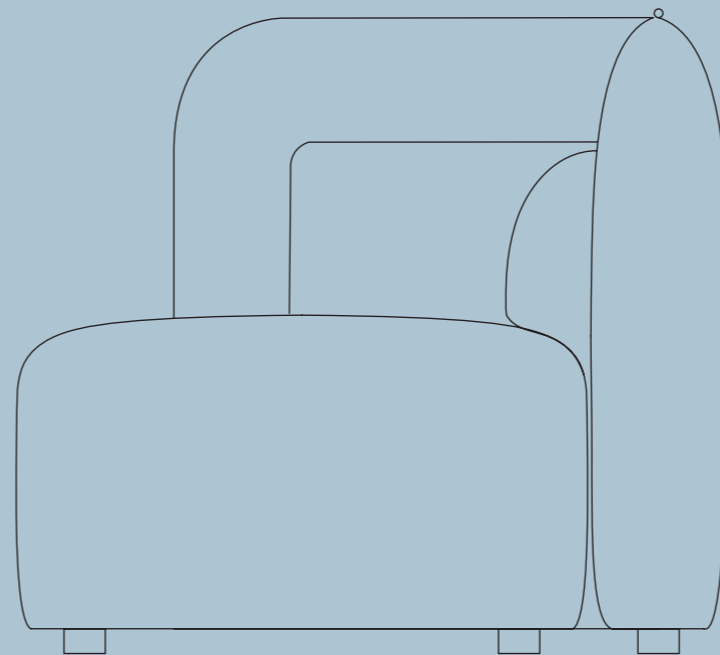

# sofas

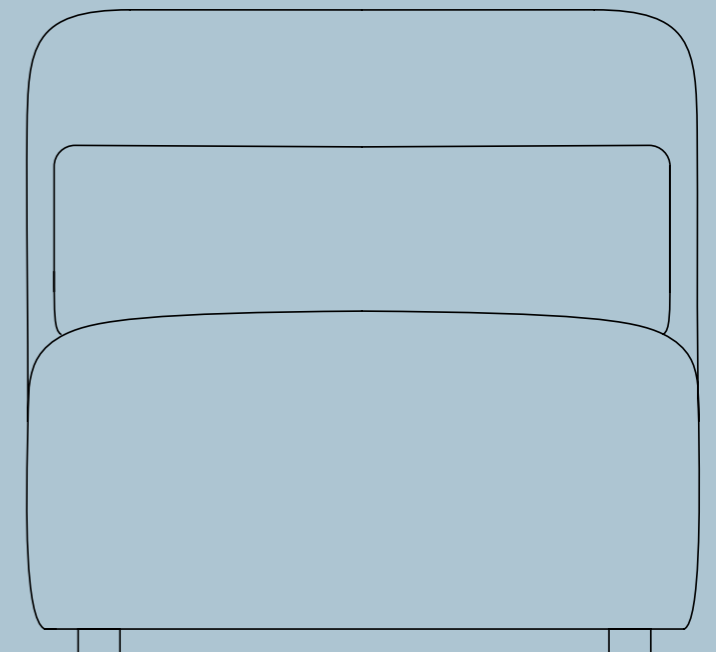

# Adam

2/3 SEATERS

VOLUME 7.0

163



ADAM SOFA 3 SEATERS

VOLUME 7.0

164



ADAM SOFA 2 SEATERS

INNOVA

Adam Sofa is the most adult member of this family with its young shapes. It maintains appearances and offers two or three places, depending on the room needed on the sofa.

Adam Sofa è il rappresentante più adulto di questa famiglia dalle forme giovani. Si dà un contegno e si fa in due o tre, a seconda dei posti necessari sul divano.

**FAMILY PRODUCT**

SOFAS



KYO SOFA LOW

VOLUME 70

165

INNOVA



Always more: from a king to the emperor! The Kyo's crown becomes more prestigious for the Kyo Sofa. It is perfect to isolate himself in the office, in the hall of an hotel or in the theatre foyer.

Sempre di più: da re a imperatore! La corona di cui si cinge Kyo diventa ancora più prestigiosa per Kyo Sofa. Perfetta per isolarsi in ufficio, nella hall di un albergo e nel foyer di un teatro.

FAMILY PRODUCT

DIVANI

Kyo  
HIGH & LOW

VOLUME 70



166

INNOVA



KYO SOFA HIGH

# Kat

SOFAS

VOLUME 7.0

167

INNOVA



DIVANI



VOLUME 7.0

168

INNOVA



As the chair to which it combines, the Kat sofa has a slight and delicate structure; it has an essential architecture that kindly sustains the seat.

Come la sedia cui si abbina, il divano Kat ha una struttura esile e leggera, un'architettura essenziale che sorregge con gentilezza la seduta.

**FAMILY PRODUCT**

# Bases



L42



L39



P24



S12



Always larger! Berg Sofa transforms the vertical grandeur of Berg high and expands it in a further in the horizontal, with a two-seat version with different bases.

Sempre più grande! Berg Sofa trasforma l'imponenza verticale di Berg Hight e la espande in un ulteriore sviluppo orizzontale, versione due posti e con diversi basamenti.

FAMILY PRODUCT

# Berg

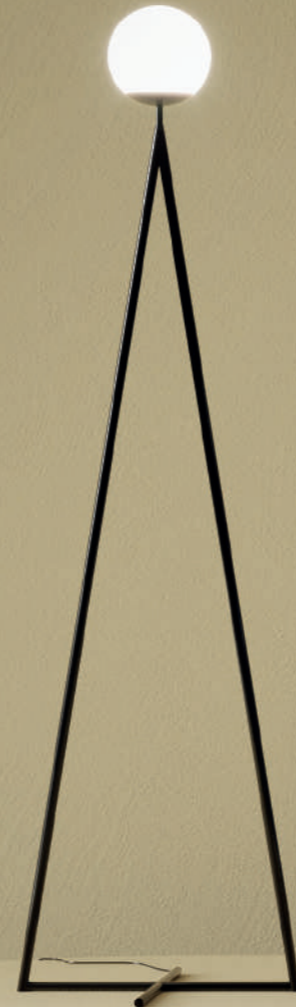

# Arsenale

GL1

SOFAS

VOLUME 7.0

171

INNOVA



DIVANI

VOLUME 7.0

172

INNOVA



An essential sofa that combines modern forms with the contemporary taste of slow living: soft lines and sober colours give lightness and warmth to the environment.

Un divano essenziale che coniuga la modernità delle forme al gusto contemporaneo dello slow living: linee morbide e colori sobri che danno alla casa luminosità e calore.

**FAMILY PRODUCT**

SOFAS

VOLUME 70



173



INNOVA

As the armchair to which it combines, the Arsenale sofa is characterized by detail of the wooden basement set up with the seat.

Come la poltroncina cui si abbina, il divano Arsenale è caratterizzato dalla particolarità del gioco d'incastro delle gambe con la seduta.

FAMILY PRODUCT

DIVANI

# Arsenale

LC1

VOLUME 70

174



INNOVA

# Circus

LOW

VOLUME 7.0

175

INNOVA



VOLUME 7.0

176

INNOVA



The same wrapping metal structure, but with twiced space for the sofa-version of Circus low. A softness easily inserted into a wide range of settings, with the exuberance of contrasting fabrics.

Stessa struttura avvolgente in metallo, ma spazio raddoppiato per la versione sofa di Circus Low. Una morbidezza facile da inserire nei contesti più diversi, con l'allegria dei tessuti a contrasto.

**FAMILY PRODUCT**

SOFAS



VOLUME 70

177

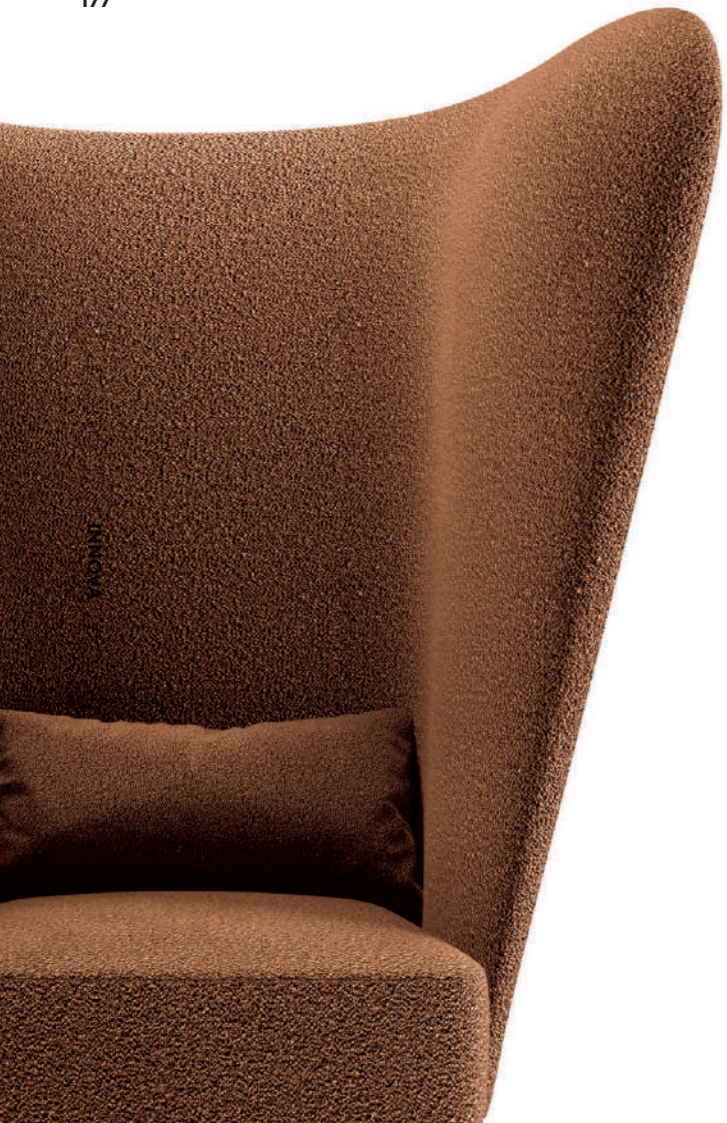

Circus High continues the family tradition of the light-hearted exaggeration of the very high backrest. This creates different worlds to experience with who we like the most.

Circus High prosegue la tradizione di famiglia dell'allegra esagerazione dello schienale, molto alto. Si creano così mondi a parte da vivere a piacere con chi ci piace di più.

FAMILY PRODUCT

DIVANI

# Circus

HIGH

VOLUME 70

178



INNOVA

# Brezza

SOFAS

VOLUME 7.0

179

INNOVA



DIVANI



SINGLE ELEMENT

VOLUME 7.0



SOFA 2 SEATERS

180



COMPOSITION

INNOVA

The wind that caresses the sea carrying the waves gives life to Brezza. Sinuous shapes that repeat themselves, creating modular games of comfort and ethereal beauty.

Il vento che accarezza il mare trasportando le onde dà vita a Brezza. Forme sinuose che si ripetono, creando giochi componibili di comodità ed eterea bellezza.

SOFAS

DIVANI

# Brezza

XL

VOLUME 70



COMPOSITION

181



INNOVA

Like the daytime breeze dances from land to sea, so the nighttime one gently retreats from the seashore to the shore, offering a well-deserved rest. Let yourself be carried away by the new XL version of Brezza, super soft and spacious, where sweet idleness becomes an unforgettable experience.

Come la brezza diurna danza dalla terra al mare, così quella notturna si concede dolcemente dalla sponda marina alla riva, offrendo un meritato riposo. Lasciatevi trasportare dalla nuova versione XL di Brezza, super morbida e spaziosa, dove il dolce far niente diventa un'esperienza indimenticabile.

VOLUME 70

182



INNOVA

# Noa

SOFAS

VOLUME 7.0

183



INNOVA



DIVANI



CENTRAL



ISLAND

VOLUME 7.0



CENTRAL + ISLAND

184



INNOVA

Noa is like a "Tetris": a few shapes are enough to be able to create various settlements at will. The different backrests, on the other hand, create infinite comfort options.

Noa è come un "Tetris": bastano poche forme per poter creare svariate composizioni a piacimento. I differenti schienali invece creano infinite opzioni di confortevolezza.

# Ideas of compositions

VOLUME 7.0

Imagine immersing yourself in product design as a magical journey back to childhood, where creative freedom transports you to enchanted realms. It's like returning to play with Lego, where each connection opens the door to new adventures

Immagina di immergerti nella progettazione di prodotti come un magico viaggio verso l'infanzia, dove la libertà creativa ti trasporta in mondi incantati. È come tornare a giocare con i Lego, dove ogni connessione ti apre le porte a nuove avventure

VOLUME 7.0

185

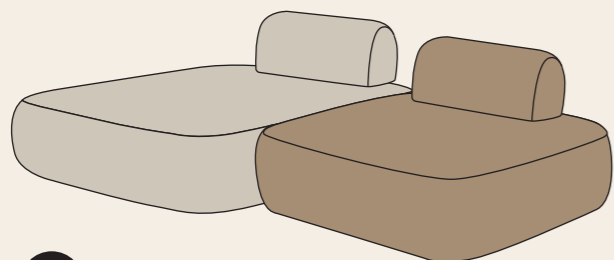

1

Composition with island + pouf elements

2

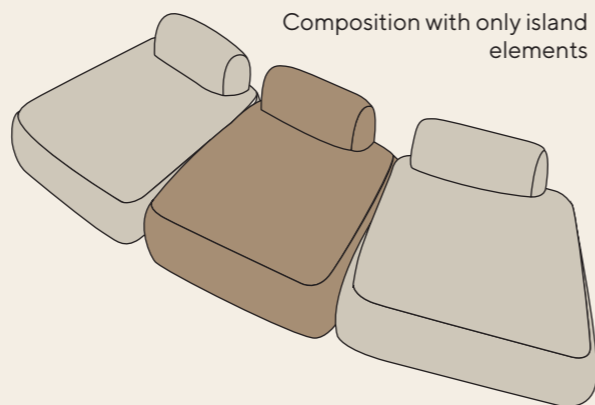

Composition with only island elements

INNOVA

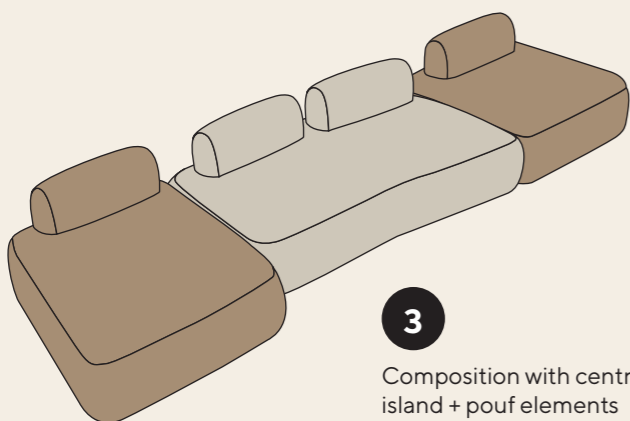

3

Composition with central + island + pouf elements

186

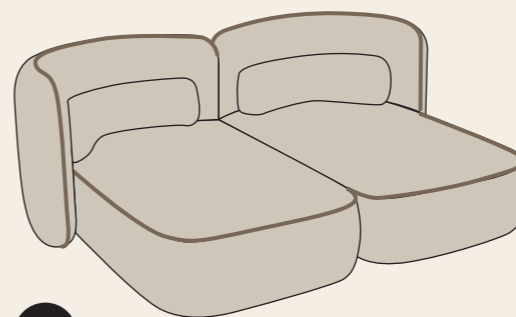

1

Composition with two chaise longue

2

Composition with chaise longue, central element and lateral XL element

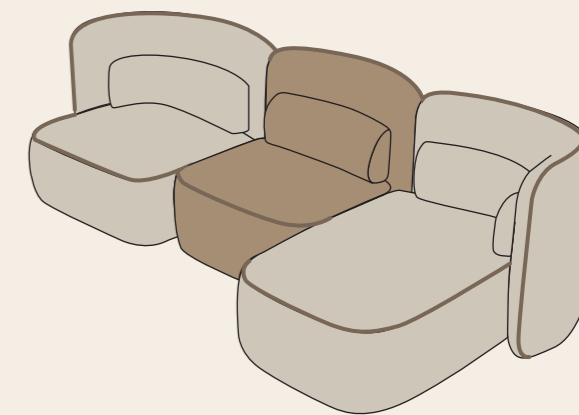

3

Composition with lateral, central element and only lateral seat

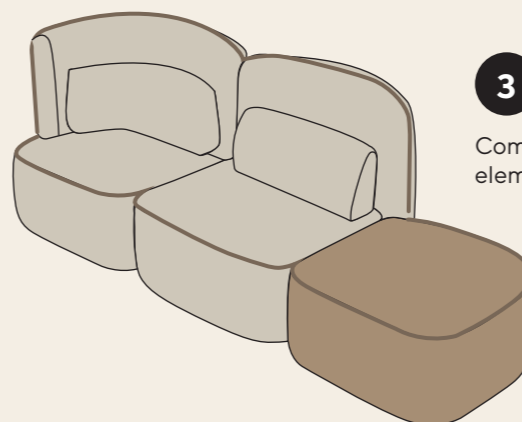

4

Composition with lateral element and only lateral XL seat element

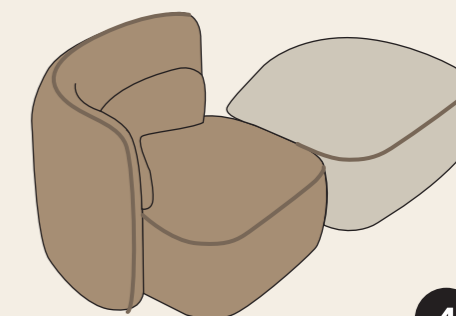

5

Composition with two XL element and two normal element, this composition can carry on without limits.

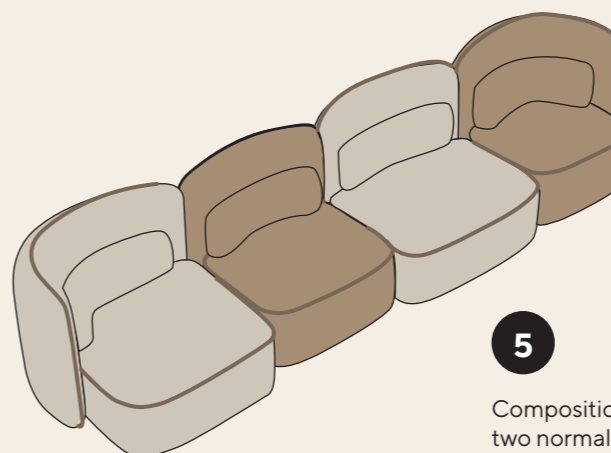

INNOVA

SOFAS



VOLUME 7.0

187



INNOVA

Nobu doubles its display of fabric in the sofa version, expressing more the soft shapes in contrast with the turned wooden base.

Nobu raddoppia la sua esibizione di tessuto nella versione divano, esprimendo maggiormente le forme morbide a contrasto con il basamento in legno tornito.

FAMILY PRODUCT

DIVANI

# Nobu



VOLUME 7.0

188

INNOVA

# Mella

SOFAS

VOLUME 7.0

189

INNOVA



DIVANI



MELLA SOFA BM14

VOLUME 7.0

190

INNOVA



MELLA SOFA GM

Immersed in the sweetness of Mella, the sofa of this collection embodies the elegance and the beauty of the soft and sinuous shapes of candies.

Immerso nella dolcezza di Mella, il divano di questa collezione incarna l'eleganza e la bellezza delle forme morbide e sinuose delle caramelle.

**FAMILY PRODUCT**

# Reference



Noa & Gin

Bergeblick Hotel

## Adam 2/3 seaters

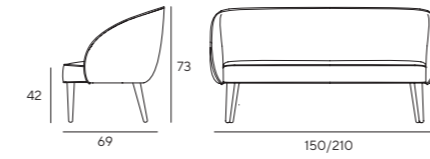

## Kat

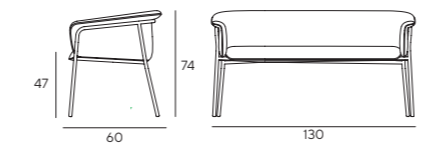

## Arsenale

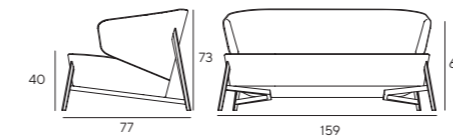

## Circus low

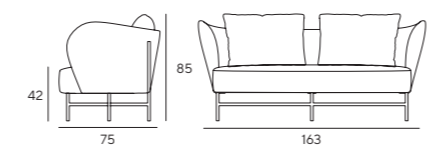

## Brezza

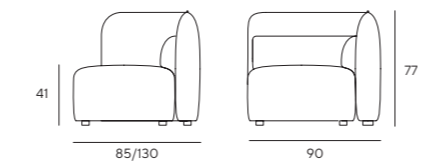

## Noa

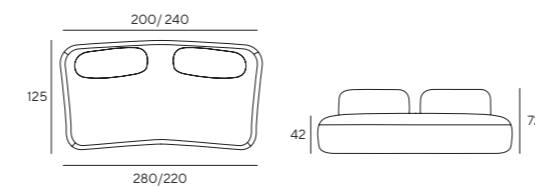

## Nobu

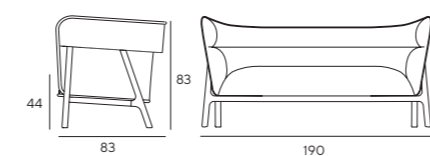

## Kyo High or Low

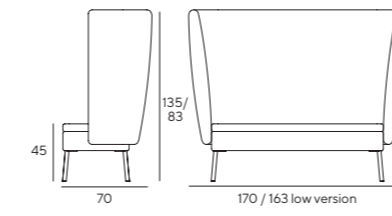

## Berg

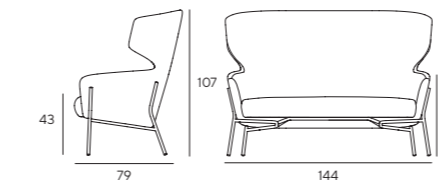

## Circus high

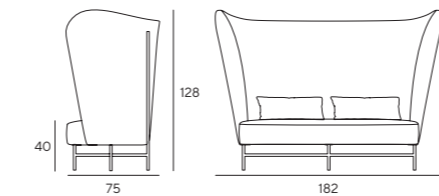

## Brezza XL

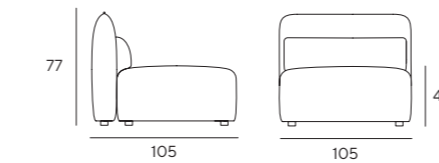

## Noa

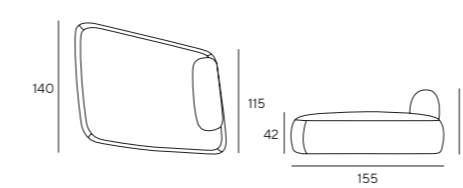

## Mella

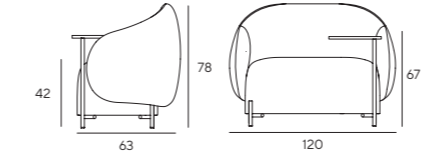

## Adam 2/3 seaters

L-C

**Composition:** The structure of the body is in solid wood and curved plywood, upholstered with expanded polyurethane foam and dacron.  
**Composizione:** Struttura della scocca in legno massello e composito curvato, imbottitura in poliuretano espanso e dacron.  
**Weight / Peso:** sofa 2 seaters 45 kg / sofa 3 seaters 50 kg  
**Required fabric / Tessuto occorrente:** sofa 2 seaters 4,30 m. (h 1,40) / sofa 3 seaters 5,50 m. (h 1,40).

## Kat

R

**Composition:** The structure of the body is in solid wood and curved plywood, upholstered with expanded polyurethane foam and dacron.  
**Composizione:** Struttura della scocca in legno massello e composito curvato, imbottitura in poliuretano espanso e dacron.  
**Weight / Peso:** 23 kg  
**Required fabric / Tessuto occorrente:** 3,50 m. (h 1,40).

## Arsenale

L-C

**Composition:** The structure of the body is in solid wood and curved plywood, upholstered with expanded polyurethane foam and dacron.  
**Composizione:** Struttura della scocca in legno massello e composito curvato, imbottitura in poliuretano espanso e dacron.  
**Weight / Peso:** 38 kg  
**Required fabric / Tessuto occorrente:** 4,30 m. (h 1,40).

## Circus Low

L-C

**Composition:** The structure of the body is in solid wood and curved plywood, upholstered with expanded polyurethane foam and dacron.  
**Composizione:** Struttura della scocca in legno massello e composito curvato, imbottitura in poliuretano espanso e dacron.  
**Weight / Peso:** 40 kg  
**Required fabric / Tessuto occorrente:** 7,00 m. (h 1,40).

## Brezza

L-C-B

**Composition:** The structure of the body is in solid wood and curved plywood, upholstered with expanded polyurethane foam and dacron.  
**Composizione:** Struttura della scocca in legno massello e composito curvato, imbottitura in poliuretano espanso e dacron.  
**Weight / Peso:** single element from 20 to 30 kg  
**Required fabric / Tessuto occorrente:** side element 4,50 m. (h 1,40) / central element 4,00 m. (h 1,40) / chaise longue 5,50 m. (h 1,40).

## Noa

L-XL

**Composition:** The structure of the body is in solid wood. Expanded polyurethane foam, seat foam and dacron.  
**Composizione:** Struttura della scocca in legno massello, imbottitura in poliuretano espanso a quote differenziate, sedile in poliuretano e dacron.  
**Weight / Peso:** central from 57 to 62 kg, island 36 kg, pouf 28 kg  
**Required fabric / Tessuto occorrente:** central 200 cm 6,50 m. (h 1,40) / central 240 cm 7,50 m. / island 6,00 m. (h 1,40) / cushion 2,00 m. each (h 1,40) / pouf 4,00 m. (h 1,40)

## Nobu

L-C-B

**Composition:** The structure of the body is in solid wood and curved plywood, upholstered with expanded polyurethane foam and dacron.  
**Composizione:** Struttura della scocca in legno massello e composito curvato, imbottitura in poliuretano espanso e dacron.  
**Weight / Peso:** 55 kg  
**Required fabric / Tessuto occorrente:** sofa complete 8,00 m. (h 1,40) / only piping 3,00 m. (h 1,40).

## Kyo High or Low

R

**Composition:** The structure of the body is in solid wood and curved plywood, upholstered with expanded polyurethane foam and dacron.  
**Composizione:** Struttura della scocca in legno massello e composito curvato, imbottitura in poliuretano espanso e dacron.  
**Weight / Peso:** Kyo High 55 kg - Kyo Low 45 kg  
**Required fabric / Tessuto occorrente:** Kyo High 8,00 m. (h 1,40) / Kyo Low 5,50 m. (h 1,40)

## Berg

L-C

**Composition:** Structure with metal inner frame entirely moulded in cold-cure polyurethane. Seat cushion with a system **SPRING PACK**, for higher comfort.  
**Composizione:** Struttura in metallo interamente stampata in poliuretano schiumato a freddo. Sedile con sistema **SPRING PACK**, per una maggiore confortevolezza.  
**Weight / Peso:** from 25 kg to 35  
**Required fabric / Tessuto occorrente:** 4,50 m. (h 1,40) / only headrest 1,00 m. (h 1,40) each.

## Circus High

L-C-B

**Composition:** The structure of the body is in solid wood and curved plywood, upholstered with expanded polyurethane foam and dacron.  
**Composizione:** Struttura della scocca in legno massello e composito curvato, imbottitura in poliuretano espanso e dacron.  
**Weight / Peso:** 70 kg  
**Required fabric / Tessuto occorrente:** 11,00 m. (h 1,40).

## Brezza XL

C-B

**Composition:** The structure of the body is in solid wood and curved plywood, upholstered with expanded polyurethane foam and dacron.  
**Composizione:** Struttura della scocca in legno massello e composito curvato, imbottitura in poliuretano espanso e dacron.  
**Weight / Peso:** single element from 25 to 35 kg  
**Required fabric / Tessuto occorrente:** side element 5,00 m. (h 1,40) / central element 4,50 m. (h 1,40) / chaise longue 6,00 m. (h 1,40).

## Mella

L

**Composition:** The structure of the body is in solid wood and curved plywood, upholstered with expanded polyurethane foam and dacron. Metal varnished legs.  
**Composizione:** Struttura della scocca in legno massello e composito curvato, imbottitura in poliuretano espanso e dacron. Gambe in metallo.  
**Weight / Peso:** 27 kg  
**Required fabric / Tessuto occorrente:** 3,50 m. (h 1,40)

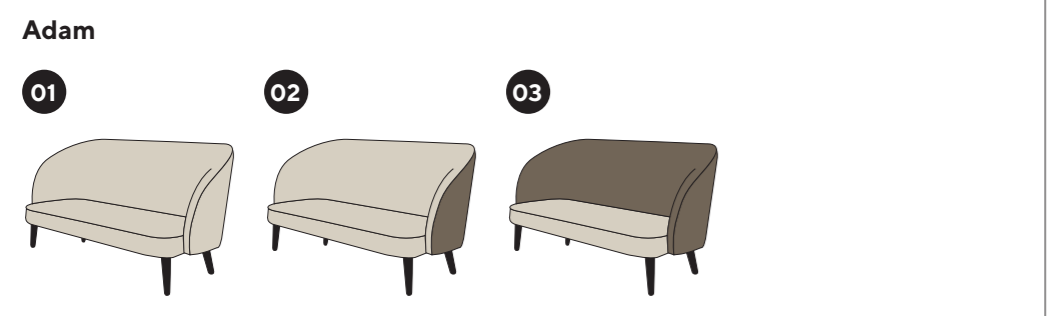

- Option 1**  
unique fabric
- Option 2**  
one fabric for the outside backrest and another for the rest
- Option 3**  
one fabric for the seat another for the backrest

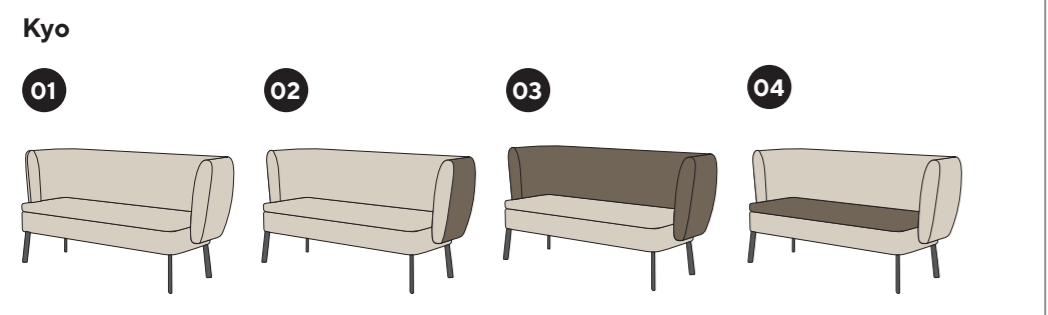

- Option 1**  
unique fabric
- Option 2**  
one fabric for the outside backrest and another for the rest
- Option 3**  
one fabric for the seat another for the backrest
- Option 4**  
two different mixed fabrics

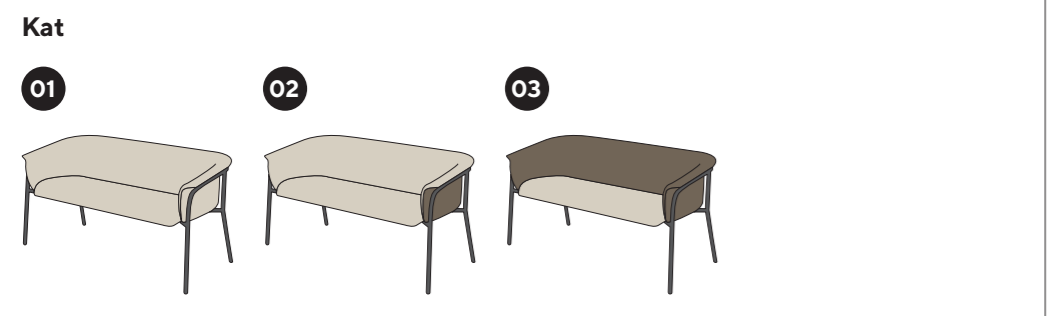

- Option 1**  
unique fabric
- Option 2**  
one fabric for the outside backrest and another for the rest
- Option 3**  
one fabric for the seat another for the backrest

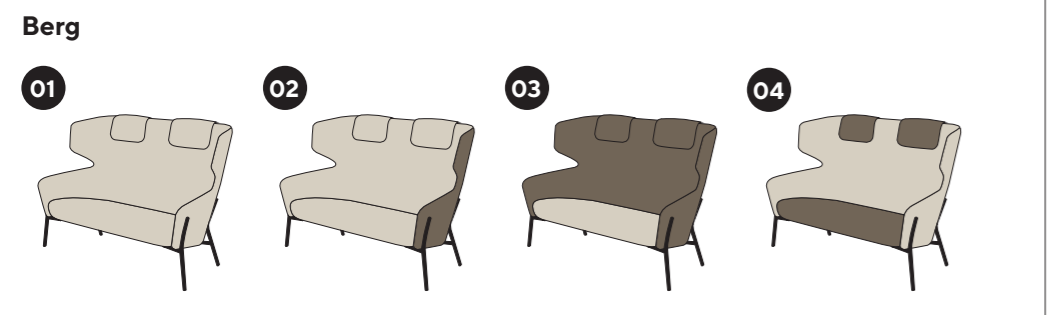

- Option 1**  
unique fabric
  - Option 2**  
one fabric for the outside backrest and another for the rest
  - Option 3**  
one fabric for the seat another for the backrest
  - Option 4**  
two different mixed fabrics
- NB: headrest it's a optional**

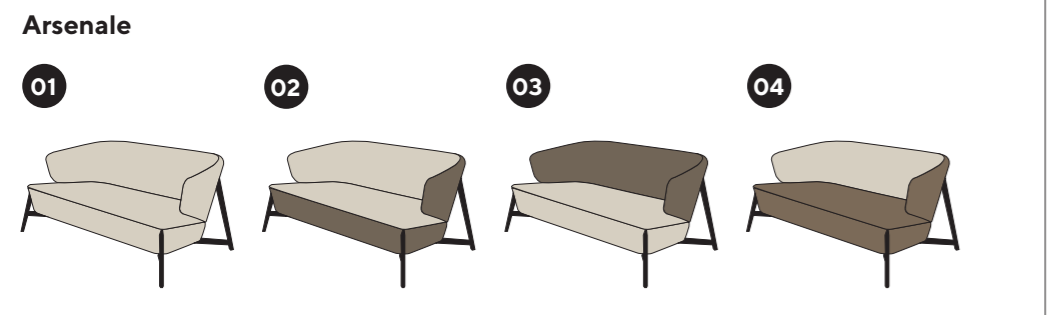

- Option 1**  
unique fabric
- Option 2**  
one fabric for the outside backrest and another for the rest
- Option 3**  
one fabric for the seat another for the backrest
- Option 4**  
two different mixed fabrics

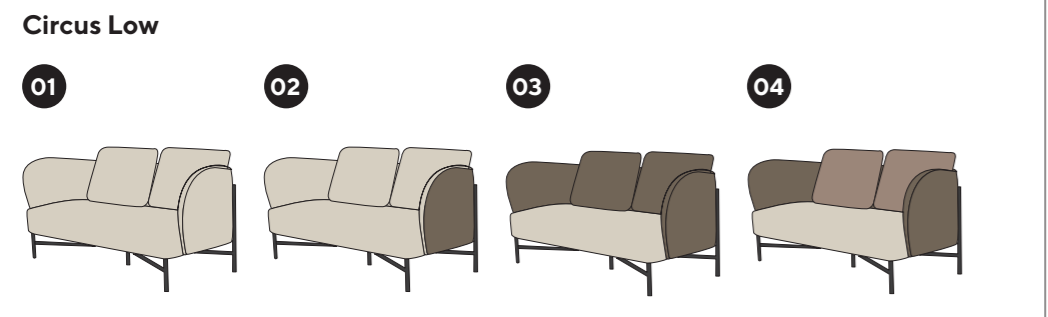

- Option 1**  
unique fabric
- Option 2**  
one fabric for the inner part and another for the outside
- Option 3**  
one fabric for the seat another for the backrest
- Option 4**  
two different mixed fabrics

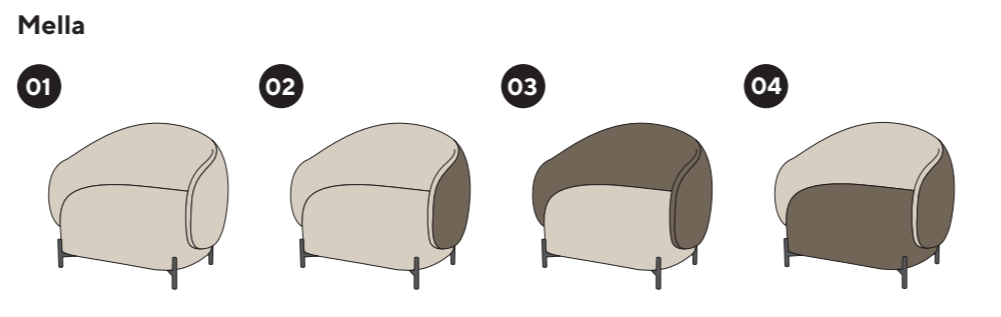
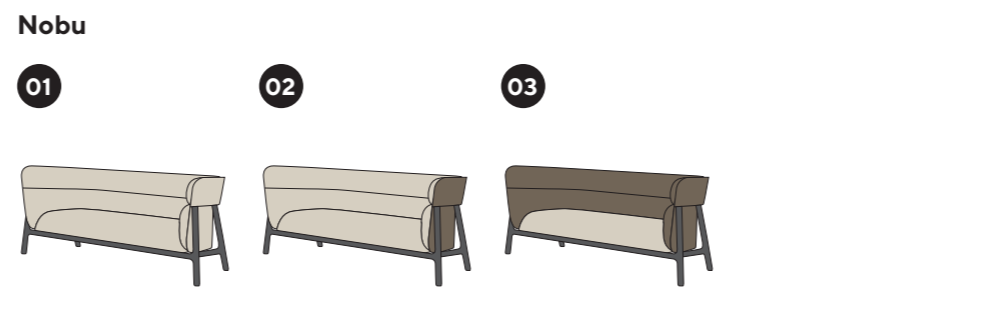
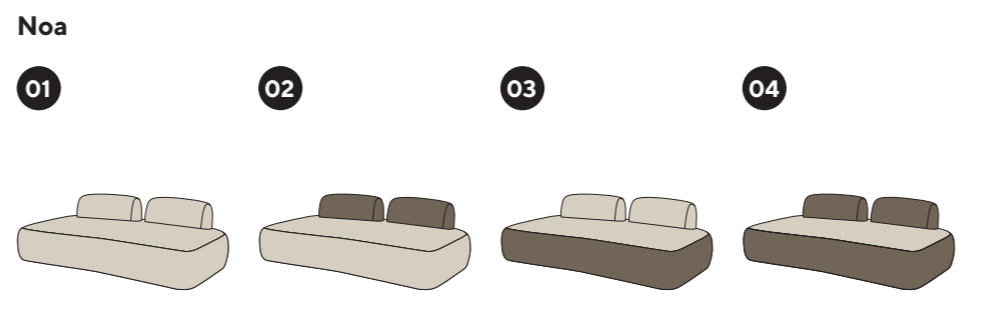
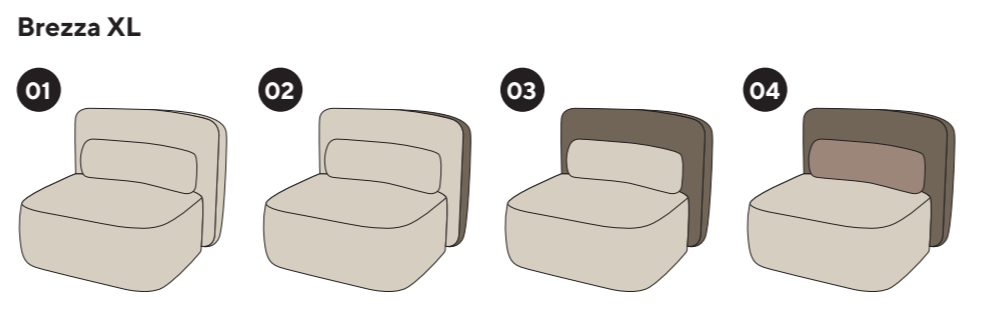
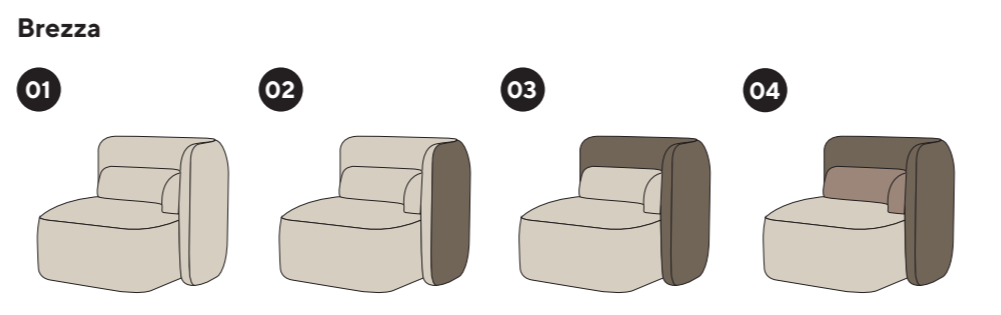
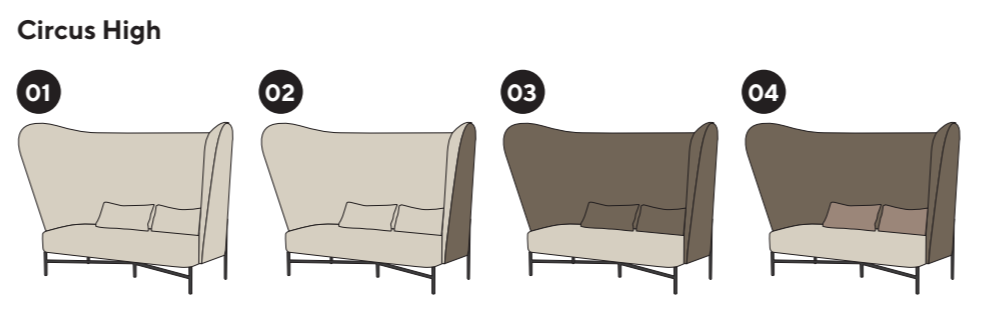

- Option 1**  
unique fabric
- Option 2**  
one fabric for the inner part and another for the outside
- Option 3**  
one fabric for the seat another for the backrest
- Option 4**  
two different mixed fabrics

- Option 1**  
unique fabric
  - Option 2**  
one fabric for the outside backrest and another for the rest
  - Option 3**  
one fabric for the seat another for the backrest
  - Option 4**  
two different mixed fabrics
- NB: piping will be the same colour as the outside fabric**

- Option 1**  
unique fabric
  - Option 2**  
one fabric for the outside backrest and another for the rest
  - Option 3**  
one fabric for the seat another for the backrest
  - Option 4**  
two different mixed fabrics
- NB: piping will be the same colour as the outside fabric**

- Option 1**  
unique fabric
- Option 2**  
one fabric for the outside backrest and another for the rest
- Option 3**  
one fabric for the seat another for the backrest
- Option 4**  
two different mixed fabrics

- Option 1**  
unique fabric
  - Option 2**  
one fabric for the outside backrest and another for the rest
  - Option 3**  
one fabric for the seat another for the backrest
  - Option 4**  
two different mixed fabrics
- NB: piping will be the same colour as the outside fabric**

- Option 1**  
unique fabric
  - Option 2**  
one fabric for the outside backrest and another for the rest
  - Option 3**  
one fabric for the seat another for the backrest
  - Option 4**  
two different mixed fabrics
- NB: piping will be the same colour as the outside fabric**

**BREZZA COMPOSITIONS**

**NB:**  
All compositions can be mixed between Brezza and Brezza XL

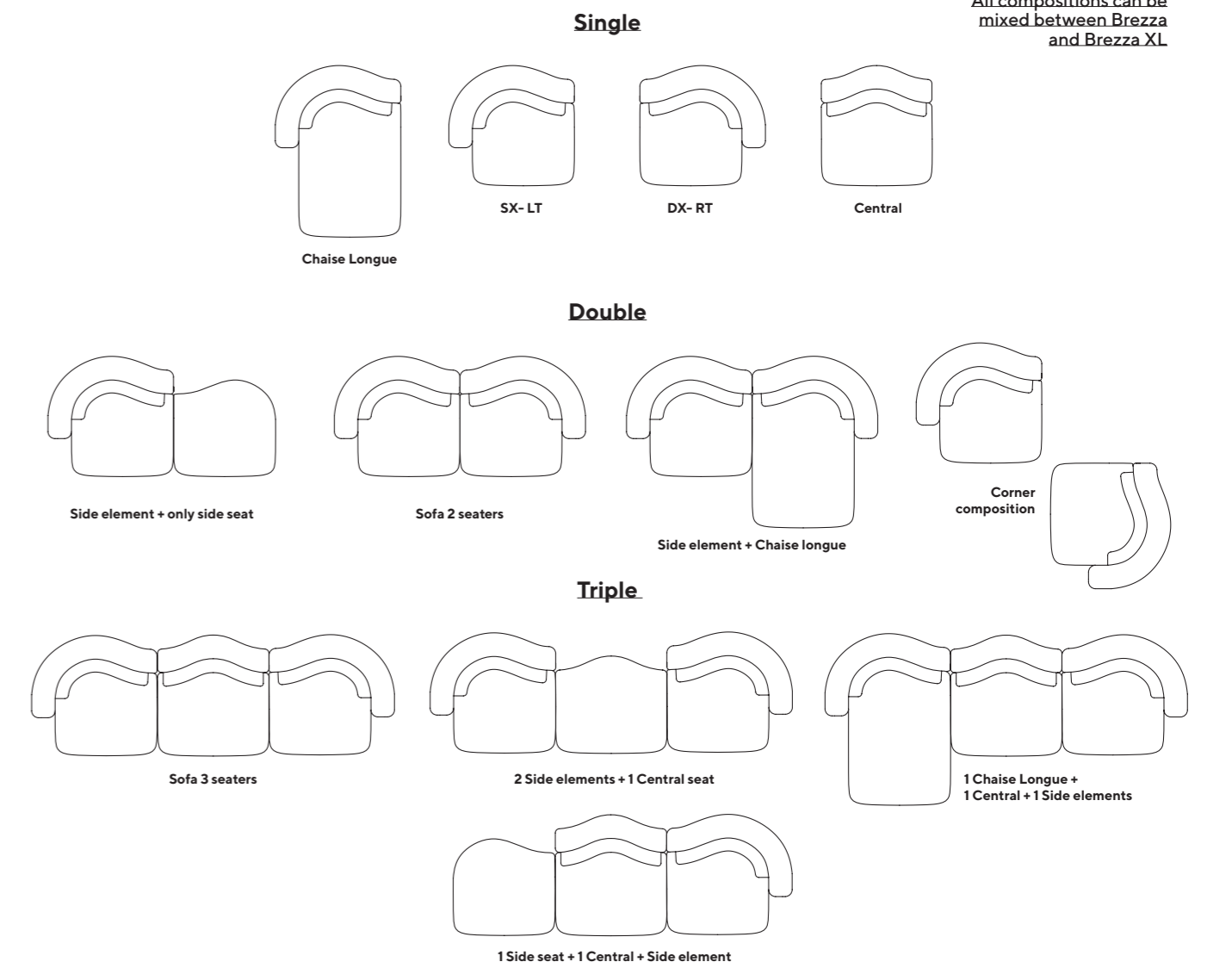

**NOA COMPOSITIONS**

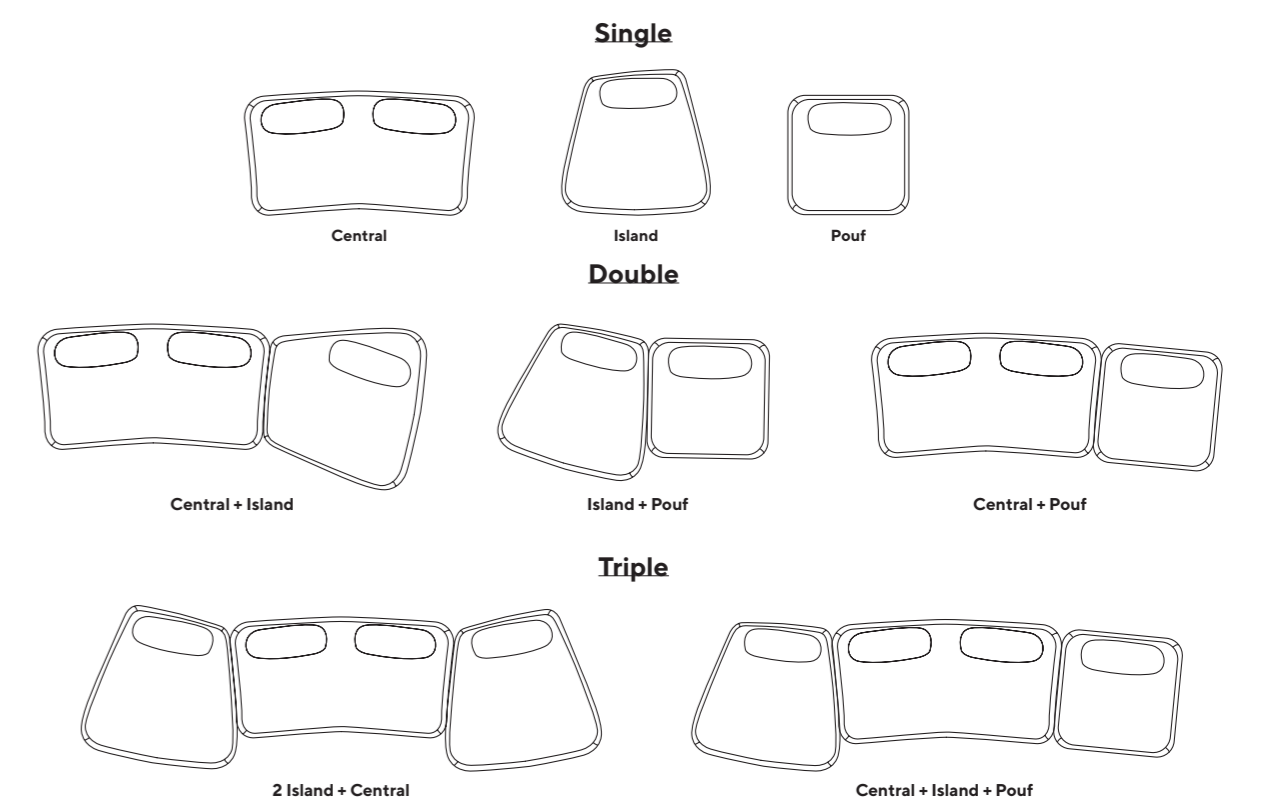

It's easy to call them footrests, coffee tables, even stools! Once discovered they instead become essential elements. These are the elements that resolve the most diverse situations, for their discretion and precision. Sometimes they present an unmistakable, special style, like no other. Other times they present simple lines to be easily combined with and support different furnishings anywhere, from bars to restaurants, from waiting rooms to the hotel reception halls, from offices to coworking stations.

Si fa presto a chiamarli pouf, tavolini, persino sgabelli! Appena scoperti diventano invece elementi essenziali. Sono quei complementi che risolvono le situazioni più diverse, discreti e precisi. A volte hanno uno stile inconfondibile, speciale come nessun'altro, altre scelgono linee semplici per abbinarsi con facilità ad arredi sempre diversi e sostenerli ovunque, dai bar ai ristoranti, dalle sale d'aspetto alle hall degli alberghi, dagli uffici ai coworking.

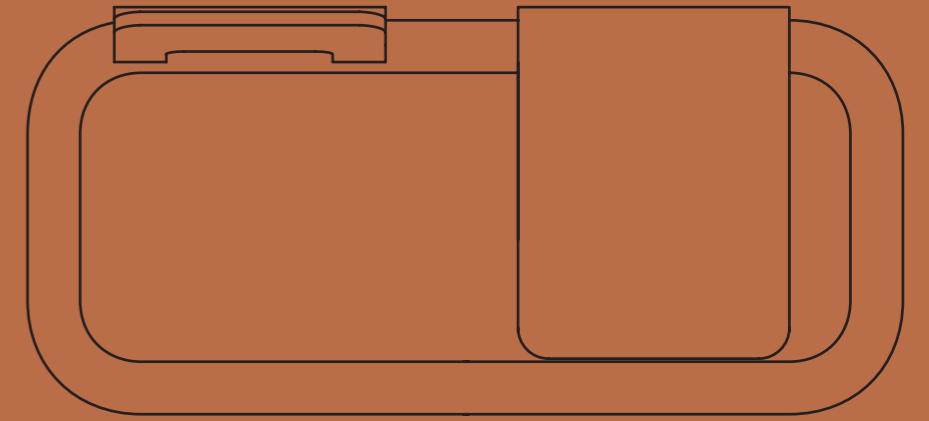
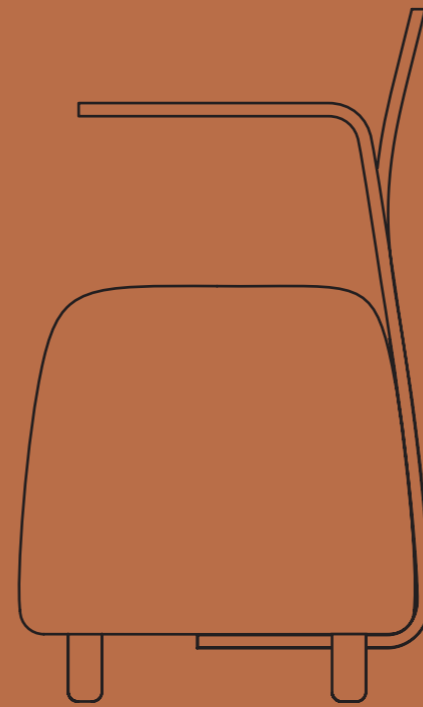

# not ordinary

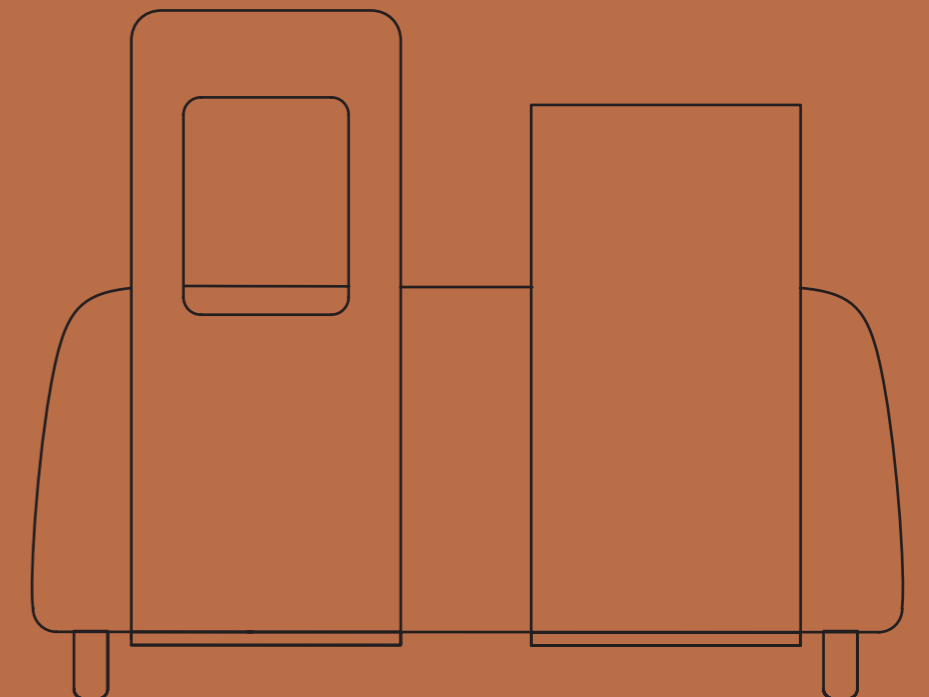

# Macaron



Our Macarons are as appetising as the desserts that give them their name. And just like them, one leads to another. They will never be enough to serve a space. Exquisitely tasty.

Sono appetibili come i dolcetti da cui prendono il nome, i nostri Macaron. E come loro, uno tira l'altro. Non saranno mai abbastanza per servire uno spazio. Sfiziosissimi.

NOT ORDINARY



TABLE



POUF

VOLUME 70

201



INNOVA

They have an instantly recognisable iconic shape, and they are a concentration of energy to be exploited: pouf or coffee table, to be moved at the speed of light, wherever they are needed. This is Moka.

Hanno una forma iconica subito riconoscibile e sono un concentrato di energia da sfruttare: pouf o tavolino, da spostare alla velocità della luce, ovunque servano. Sono i Moka.

NOT ORDINARY

# Moka



NOT ORDINARY

# Mella

VOLUME 7.0

203



INNOVA

NOT ORDINARY

## Composition



ARMCHAIR



ARMCHAIR + TABLE



SMALL SOFA+ TABLE



SMALL SOFA

Mella collection is inspired by the soft and sinuous shapes of sweets and sugared almonds. The contained and rounded dimensions of the product make the collection adaptable to any space and context.

La collezione Mella si ispira alle forme morbide e sinuose di caramelle e confetti. Le dimensioni contenute e tonde del prodotto rendono la collezione adattabile ad ogni spazio e contesto,



## Composition



HIGH TABLE



BARSTOOL



STOOL



LOW TABLE



High or low, round or triangular, always soft at the top, with a beautiful difference in the rigor of the base. All of the Ness family are adept at multitasking: chair, table, plant holder, bag rest... The choice is yours.

Alti o bassi, tondi o triangolari, dalle forme morbide contrapposte al rigoroso basamento. I membri della famiglia Ness sono multitasking: seduta, tavolo, portapiante, poggia borsa... Fai tu.

# Ness



# Vice-versa

VOLUME 7.0

207

INNOVA

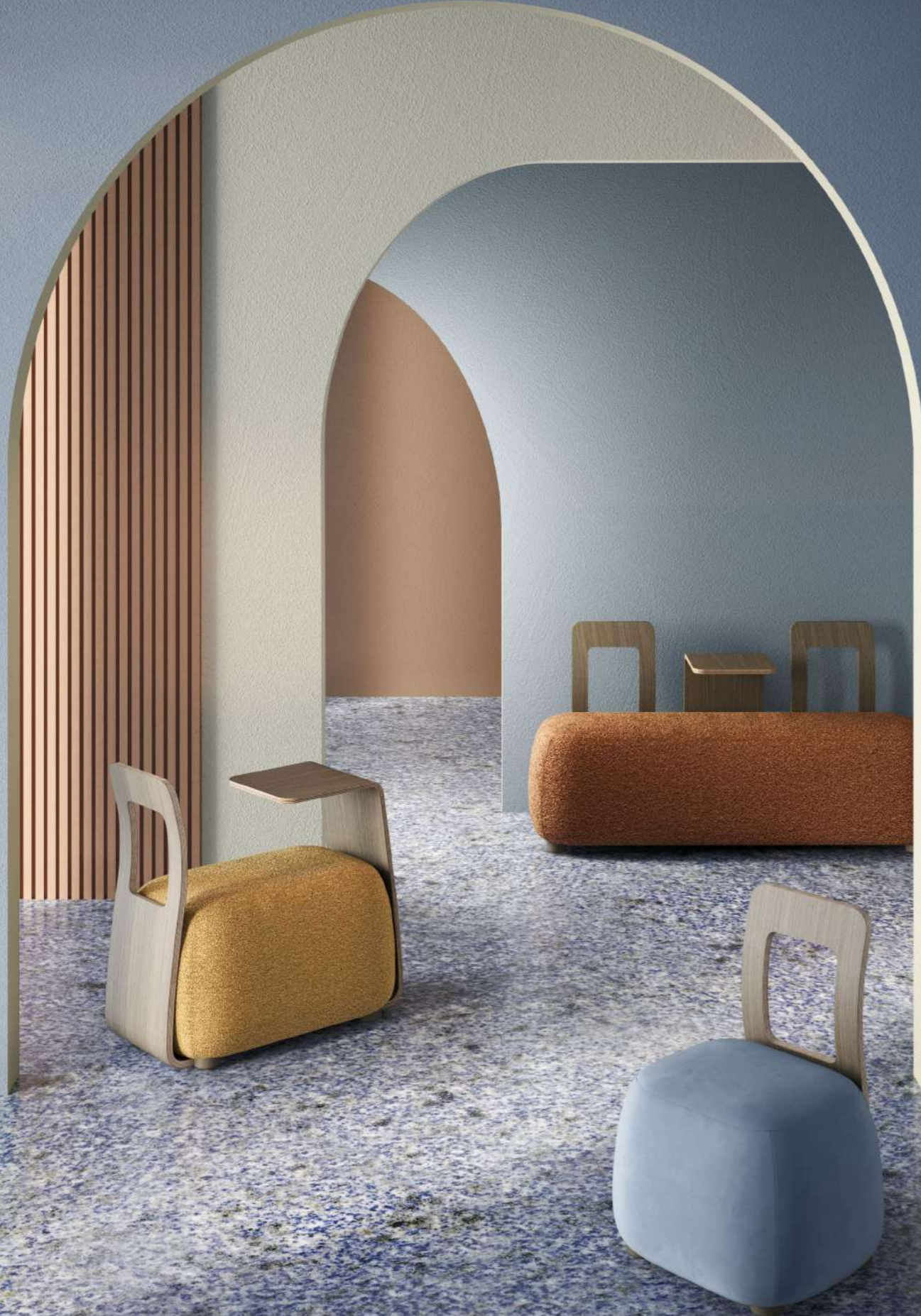

## Composition



POUF



SMALL ISLAND



SMALL BENCH

VOLUME 7.0



ISLAND

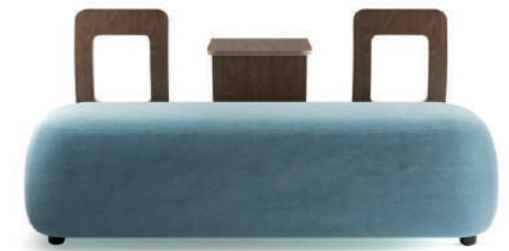

BIG BENCH

208



INNOVA

The Vice-versa collection says goodbye to boredom! Simple and elegant, its name is clear: direction doesn't matter, and the result will be what you want: chair, bedside table, bench, even a coworking station.

Con la collezione Vice-versa, noia addio! Semplice ed elegante, il suo nome è chiaro: non importa il verso, il risultato sarà ciò che vuoi: sedia, comodino, panca, persino stazione coworking.

NOT ORDINARY



VOLUME 7.0

209



INNOVA

NOT ORDINARY

# Vice-versa



VOLUME 7.0

210

INNOVA

# Reference



Mella & Tube

Die Hoch Königin

## Macaron

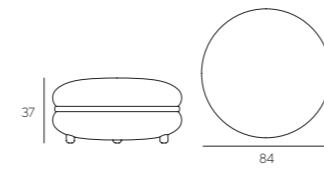

## Moka pouf & table

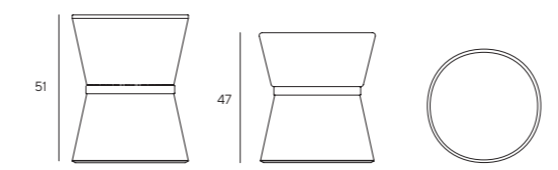

## Mella armchair

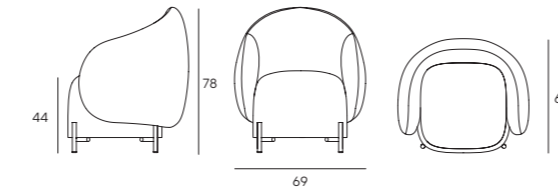

## Mella sofa

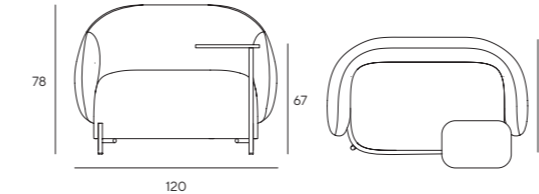

## Ness stool

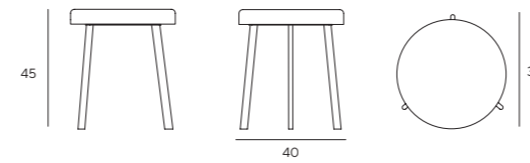

## Ness low table

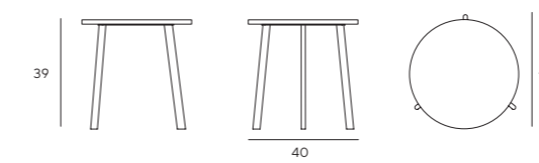

## Ness barstool

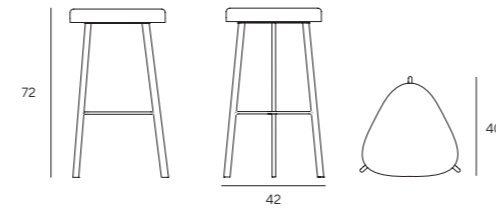

## Ness high table

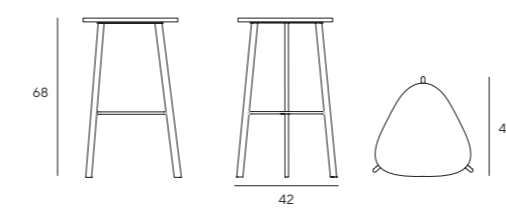

## Vice-versa pouf

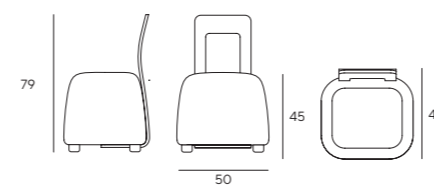

## Vice-versa small island

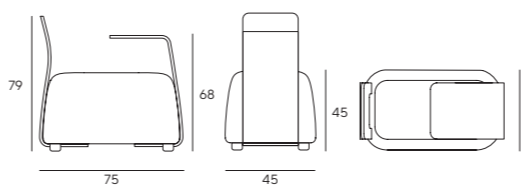

## Vice-versa small bench

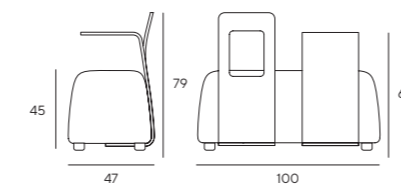

## Vice-versa big bench

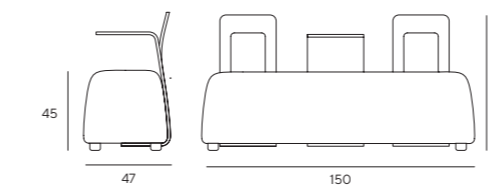

## Vice-versa island

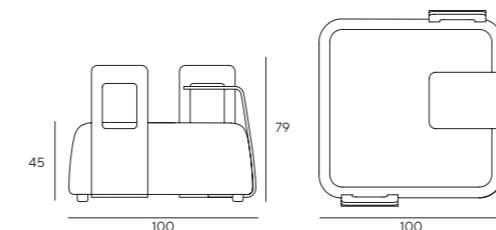

## Macaron

L-C

**Composition:** The structure of the body is in solid wood with expanded polyurethane foam.  
**Composizione:** Struttura della scocca in legno massello con imbottitura in poliuretano espanso.  
**Weight / Peso:** 20 kg  
**Required fabric / Tessuto occorrente:** pouf complete 3,00 m. (h 1,40) only central cream 0,50 m. (h 1,40).

## Moka pouf & table

R

**Composition:** The structure of the seat is in solid wood and curved plywood with expanded polyurethane foam. The base and the table are in solid curved wood. The table has the top in porcelain stoneware or in melamine finish.  
**Composizione:** Struttura della scocca in legno massello e composito curvato, imbottitura in poliuretano espanso.  
 Il basamento ed il tavolino sono in legno curvato.  
 Il tavolino ha il top in grès porcellanato o con finitura in melaminico.  
**Weight / Peso:** kg 8,2  
**Required fabric / Tessuto occorrente:** 1,00 m. (h 1,40).

## Mella armchair

L

**Composition:** The structure of the body is in solid wood and curved plywood, upholstered with expanded polyurethane foam and dacron. Metal varnished legs.  
**Composizione:** Struttura della scocca in legno massello e composito curvato, imbottitura in poliuretano espanso e dacron. Gambe in metallo.  
**Weight / Peso:** 18 kg, optional table 2 kg  
**Required fabric / Tessuto occorrente:** 3,00 m. (h 1,40)

## Mella sofa

L

**Composition:** The structure of the body is in solid wood and curved plywood, upholstered with expanded polyurethane foam and dacron. Metal varnished legs.  
**Composizione:** Struttura della scocca in legno massello e composito curvato, imbottitura in poliuretano espanso e dacron. Gambe in metallo.  
**Weight / Peso:** 27 kg, optional table 2 kg  
**Required fabric / Tessuto occorrente:** 3,50 m. (h 1,40)

## Ness stool

R

**Composition:** The structure of the body is in solid wood with expanded polyurethane foam. The basement in metal.  
**Composizione:** Struttura della scocca in legno massello con imbottitura in poliuretano espanso. Basamento in metallo.  
**Weight / Peso:** 3,5 kg  
**Required fabric / Tessuto occorrente:** 0,70 m. (h 1,40)

## Ness low table

**Composition:** Metal base with the top in porcelain stoneware or in melamine finish.  
**Composizione:** Basamento in metallo con il top in grès porcellanato o con finitura in melaminico.  
**Weight / Peso:** 4,5 kg

## Ness barstool

R

**Composition:** The structure of the body is in solid wood with expanded polyurethane foam. The basement in metal.  
**Composizione:** Struttura della scocca in legno massello con imbottitura in poliuretano espanso a quote differenziate. Basamento in metallo.  
**Weight / Peso:** 5,5 kg  
**Required fabric / Tessuto occorrente:** 0,70 m. (h 1,40)

## Ness high table

**Composition:** Metal base with the top in porcelain stoneware or in melamine finish.  
**Composizione:** Basamento in metallo con il top in grès porcellanato o con finitura in melaminico.  
**Weight / Peso:** 6,5 kg

## Vice-versa pouf

L-C-B

**Composition:** The structure of the body is in solid wood and curved plywood with expanded polyurethane foam. The backrest and the table are in solid curved wood.  
**Composizione:** Struttura della scocca in legno massello e composito curvato, imbottitura in poliuretano espanso.  
 Schienale e tavolino in legno curvato.  
**Weight / Peso:** 9 kg, backrest and table 3 kg each  
**Required fabric / Tessuto occorrente:** 1,20 m. (h 1,40).

## Vice-versa small island

L-C-B

**Composition:** The structure of the body is in solid wood and curved plywood with expanded polyurethane foam. The backrest and the table are in solid curved wood.  
**Composizione:** Struttura della scocca in legno massello e composito curvato, imbottitura in poliuretano espanso.  
 Schienale e tavolino in legno curvato.  
**Weight / Peso:** 11 kg, backrest and table 3 kg each  
**Required fabric / Tessuto occorrente:** 1,50 m. (h 1,40).

## Vice-versa small bench

L-C-B

**Composition:** The structure of the body is in solid wood and curved plywood with expanded polyurethane foam. The backrest and the table are in solid curved wood.  
**Composizione:** Struttura della scocca in legno massello e composito curvato, imbottitura in poliuretano espanso.  
 Schienale e tavolino in legno curvato.  
**Weight / Peso:** 14,5 kg, backrest and table 3 kg each  
**Required fabric / Tessuto occorrente:** 2,20 m. (h 1,40)

## Vice-versa big bench

L-C-B

**Composition:** The structure of the body is in solid wood and curved plywood with expanded polyurethane foam. The backrest and the table are in solid curved wood.  
**Composizione:** Struttura della scocca in legno massello e composito curvato, imbottitura in poliuretano espanso.  
 Schienale e tavolino in legno curvato.  
**Weight / Peso:** 23,5 kg, backrest and table 3 kg each  
**Required fabric / Tessuto occorrente:** 2,50 m. (h 1,40).

## Vice-versa island

L-C-B

**Composition:** The structure of the body is in solid wood and curved plywood with expanded polyurethane foam. The backrest and the table are in solid curved wood.  
**Composizione:** Struttura della scocca in legno massello e composito curvato, imbottitura in poliuretano espanso.  
 Schienale e tavolino in legno curvato.  
**Weight / Peso:** 47 kg, backrest and table 3 kg each  
**Required fabric / Tessuto occorrente:** 3,30 m. (h 1,40).

**Macaron**

01 02

**Ness barstool**

01 02

**Option 1**  
unique fabric

**Option 2**  
one fabric for the top and another for the bottom

**Option 1**  
unique fabric

**Option 2**  
one fabric for the top and another for the bottom

**Moka**

01 02

**Ness table high & low**

01 02 03 04

**Option 1**  
unique fabric

**Option 2**  
one fabric for the top and another for the bottom

**Option 1**  
unique fabric

**Option 2**  
one fabric for the top and another for the bottom

**Moka table**

01

**Vice-versa pouf**

01 02

**Option 1**  
unique fabric

**Option 2**  
one fabric for the top and another for the bottom

**Option 1**  
unique fabric

**Option 2**  
one fabric for the top and another for the bottom

**Mella armchair**

01 02 03 04

**Option 1**  
unique fabric

**Option 2**  
one fabric for the outside backrest and another for the rest

**Option 3**  
one fabric for the seat another for the backrest

**Option 4**  
two different mixed fabrics

**NB: piping will be the same colour as the outside fabric**

**Vice-versa small island**

01 02

**Option 1**  
unique fabric

**Option 2**  
one fabric for the top and another for the bottom

**Option 1**  
unique fabric

**Option 2**  
one fabric for the top and another for the bottom

**Mella sofa**

01 02 03 04

**Option 1**  
unique fabric

**Option 2**  
one fabric for the outside backrest and another for the rest

**Option 3**  
one fabric for the seat another for the backrest

**Option 4**  
two different mixed fabrics

**NB: piping will be the same colour as the outside fabric**

**Vice-versa small & big bench**

01 02

**Option 1**  
unique fabric

**Option 2**  
one fabric for the top and another for the bottom

**Option 1**  
unique fabric

**Option 2**  
one fabric for the top and another for the bottom

**Ness pouf**

01 02

**Option 1**  
unique fabric

**Option 2**  
one fabric for the top and another for the bottom

**Vice-versa island**

01 02

**Option 1**  
unique fabric

**Option 2**  
one fabric for the top and another for the bottom

**Option 1**  
unique fabric

**Option 2**  
one fabric for the top and another for the bottom

**VICE-VERSA COMPOSITIONS**

**Pouf:**

**Small island:**

**Small bench:**

**Big bench:**

**Island:**

True standouts in spaces for dining and conviviality, barstools are high seats that favour a posture midway between standing and sitting. Precisely for this reason, they are designed to be as comfortable as chairs and armchairs, with a footrest, padded seat and wrapping backrest. Innova has created different models, also to be combined with chairs from the same family.

Immancabili all'interno dei luoghi della ristorazione e della convivialità, gli sgabelli sono sedute alte che favoriscono una postura a metà tra lo stare in piedi e lo stare seduti. Proprio per questo, sono studiati per essere comodi al pari di sedie e poltroncine, con poggiatesta, sedile imbottito e schienale avvolgente. Innova ha ideato diversi modelli, anche da abbinare alle sedie della stessa famiglia.

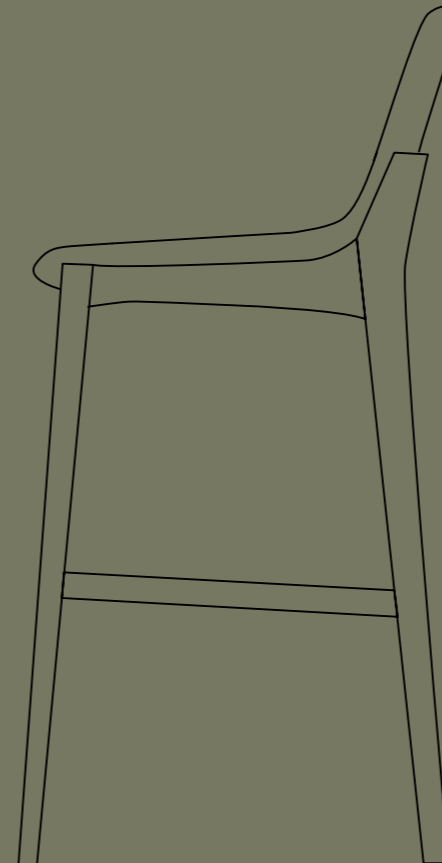
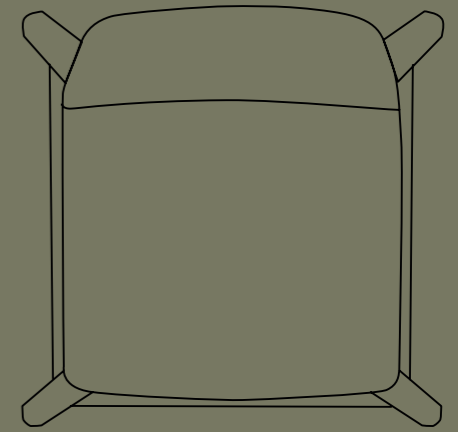

# barstools

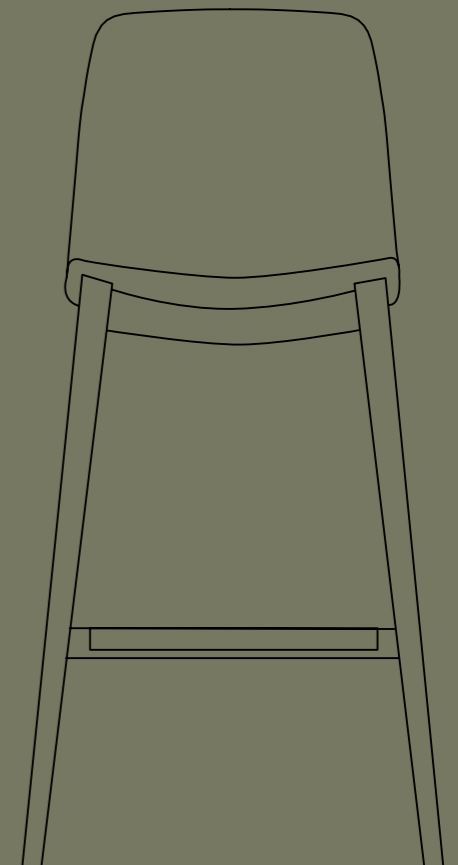

# Diamond

A padded seat with precise cuts, like a diamond, but so comfortable.

Una seduta imbottita dai tagli precisi, come un diamante, ma tanto comoda.

VOLUME 7.0

219

INNOVA



BARSTOOL



FAMILY PRODUCT

SGABELLI



FAMILY PRODUCT

# Izzy

With or without an opening in the back, this is the Izzy stool. Lively.

Con o senza apertura sullo schienale, ecco lo sgabello Izzy. Frizzante.

VOLUME 7.0

220

INNOVA



# Look

This barstool features an open form.  
Broad, sharp and always inviting.

Uno sgabello con una forma aperta, ampia e netta,  
pronta ad accogliere.

VOLUME 7.0

221

INNOVA



SG2

BARSTOOL



SG1

SGABELLI

# Ness

Ness stool, whether triangular or rounded, means  
comfort and simplicity.

Ness sgabello, triangolare o tondo a piacere, è  
comodità e semplicità.

VOLUME 7.0

222

INNOVA



FAMILY PRODUCT

FAMILY PRODUCT

# Rivolí

A structured and comfortable stool for a sophisticated and reserved environment.

Per un ambiente raffinato e riservato, uno sgabello strutturato e comodo.



VOLUME 7.0

223

INNOVA

BARSTOOL

SGABELLI

# Soho

A fresh, young and elegant stool, always ready to party.

Uno sgabello fresco, giovane ed elegante, sempre pronto a far festa.



VOLUME 7.0

224

INNOVA

FAMILY PRODUCT

FAMILY PRODUCT

Innova loves informal and convivial situations. This is when poufs, cushions and coffee tables furnish spaces and offer immediate solutions, easy to move, and improvised and perfect supports. They shine for their versatility. Like those evenings spent with a gin and tonic in hand, vibrating to the rhythm of drum and bass while looking at the sky. Only a few tacos for dinner late into the evening, before preparing two or three mokas before heading out, walking on the clouds until a breakfast of macarons.

And then? Everything vice-versa, to start over again. First a little rest, between poufs, cushions and coffee tables.

Innova ama le situazioni informali e conviviali. È allora che pouf, cuscini e tavolini arredano, sono soluzioni immediate, facili da spostare, sostegni improvvisati e perfetti. Danno il meglio della loro versatilità. Come in quelle serate da gin and tonic in mano, a vibrare al ritmo della drum and bass guardando lo sky. Solo qualche taco sotto i denti fino a tardi, per poi preparare due-tre moka e uscire, camminando sulle cloud fino a una colazione con i macaron. E dopo? Tutto vice-versa, per ricominciare. Prima un po' di riposo, fra pouf, cuscini e tavolini.

# complements

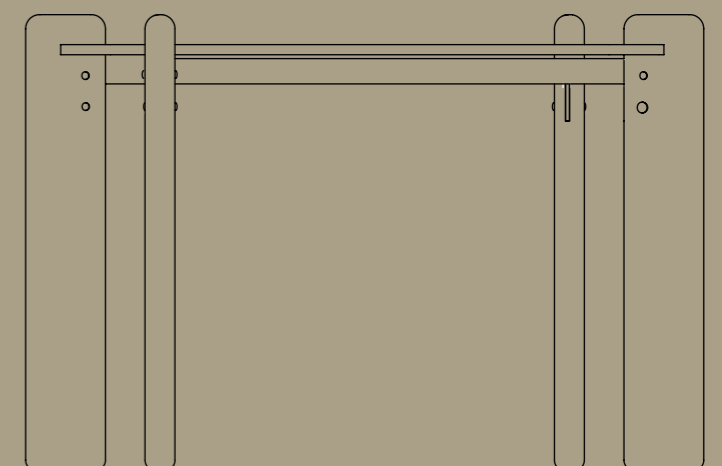
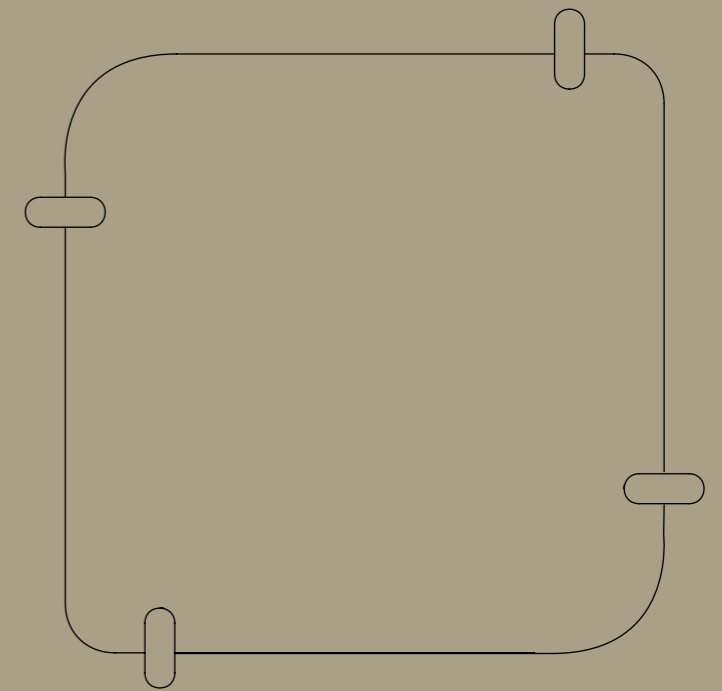



# Poufs

227



# Macaron

# Gin



228

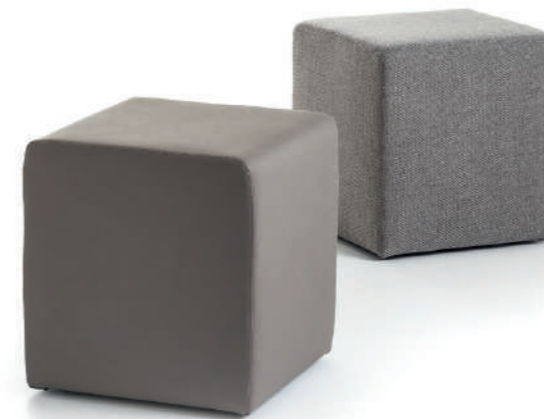

# Tonic



**Drum**



**Sky**

**Taco**



**Berg**



**Adam**



**Cloud**



**Vice-versa**  
POUF



**Vice-versa**  
BIG BENCH

**Vice-versa**  
SMALL ISLAND



**Vice-versa**  
ISLAND



**Vice-versa**  
SMALL BENCH



**Moka**

# Cushions

VOLUME 7.0



## Neep & Noop



## Basic

VOLUME 7.0

233

## Merge



## Big volant



234

INNOVA



## Ness



## Small volant

INNOVA

# Reference

VOLUME 70

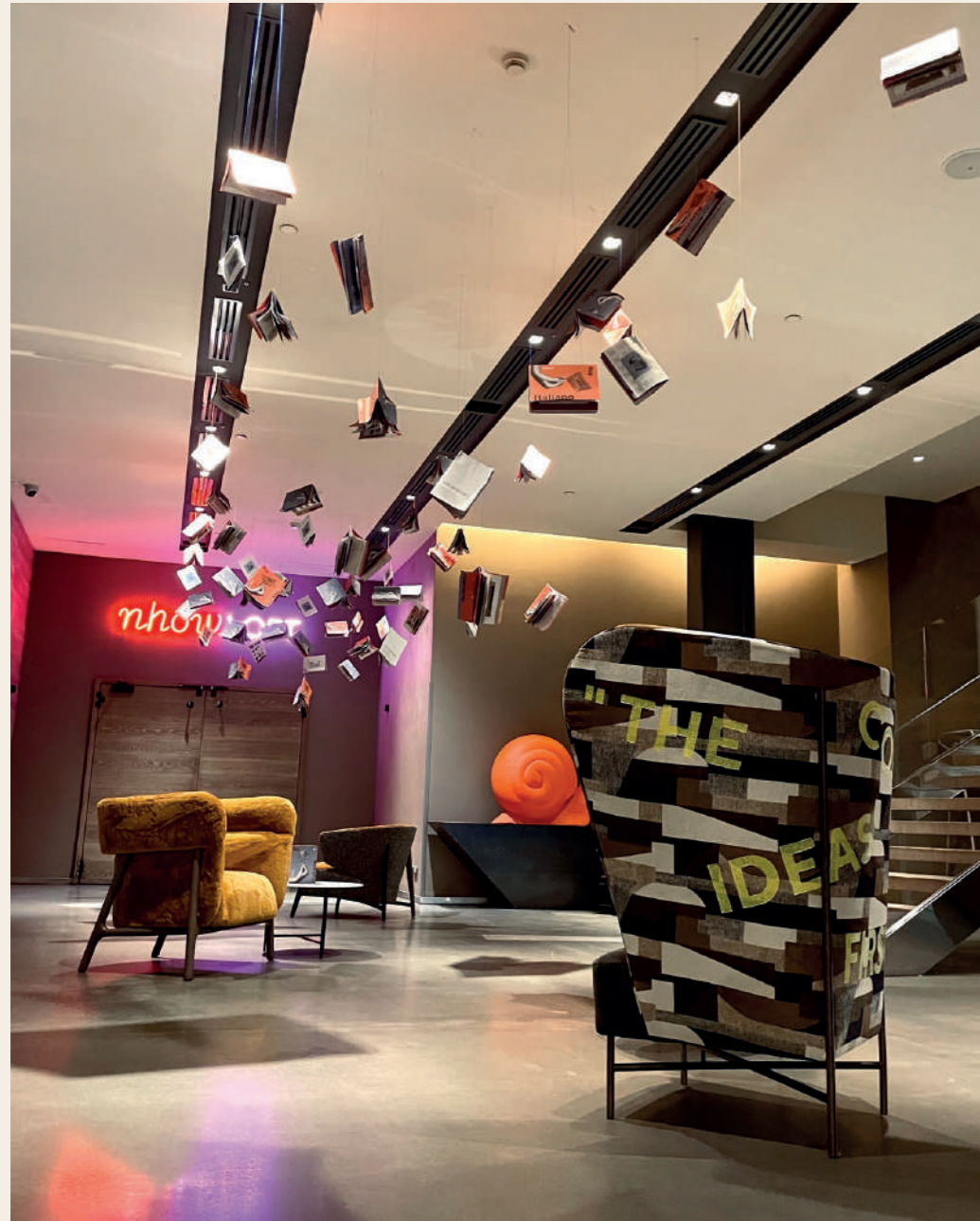

Circus, Nobu & Arsenale

Nhow Milano

235

INNOVA

## Diamond

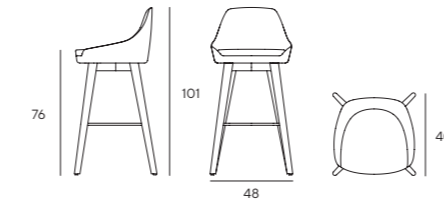

## Look

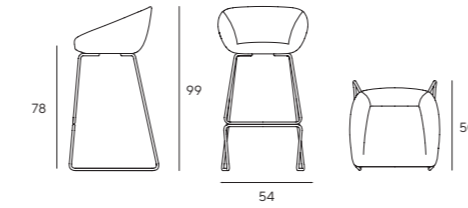

## Rivoli

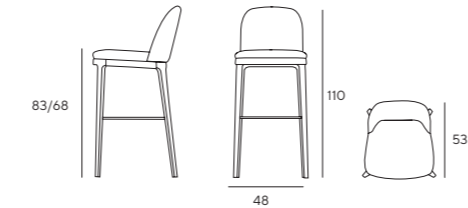

## Macaron

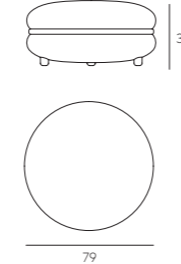

## Tonic

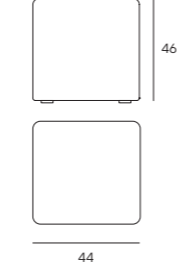

## Gin

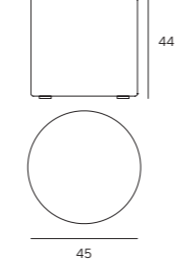

## Drum

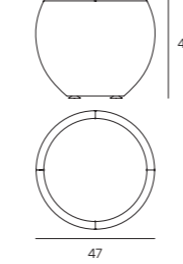

## Taco

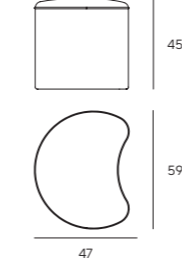

## Adam

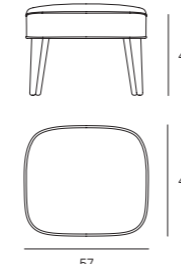

## Sky

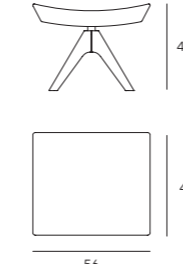

## Berg

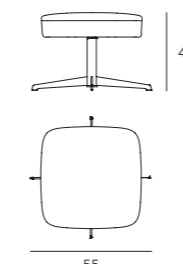

## Cloud

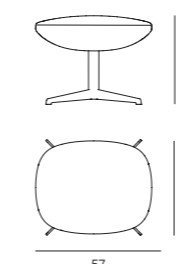

## Vice-versa

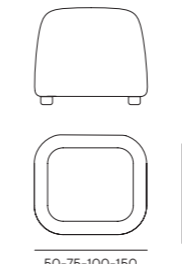

## Moka

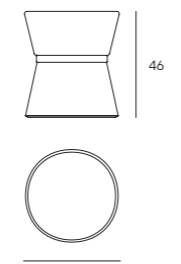

## Neep

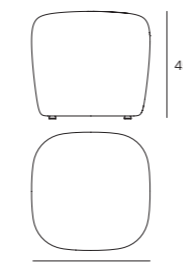

## Noop

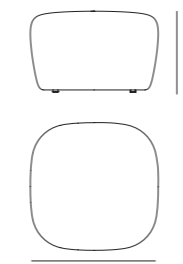

## Merge

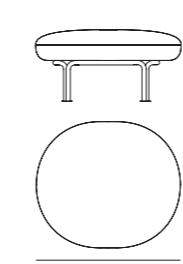

## Ness

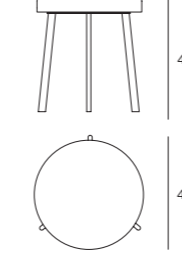

## Izzy

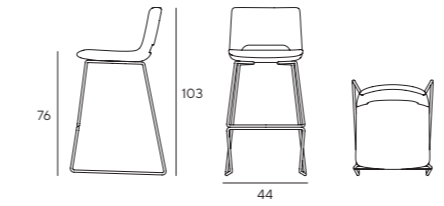

## Ness

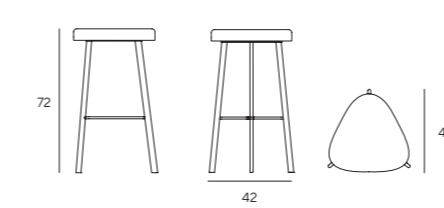

## Soho

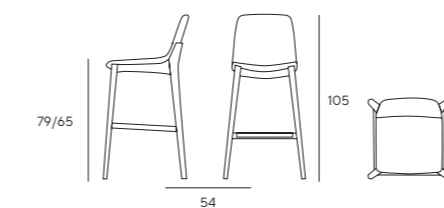

VOLUME 70

236

INNOVA

## Diamond

R-L

**Composition:** Steel framework, entirely moulded in cold-cure polyurethane.  
**Composizione:** Struttura della scocca in acciaio, interamente stampata in poliuretano schiumato a freddo.  
**Weight / Peso:** SG2 13 kg - L48 10 kg  
**Required fabric / Tessuto occorrente:** 1,20 m. (h 1,40).

## Look

R-L

**Composition:** Steel framework, entirely moulded in cold-cure polyurethane.  
**Composizione:** Struttura della scocca in acciaio, interamente stampata in poliuretano schiumato a freddo.  
**Weight / Peso:** SG2 10 kg - SG1 21 kg  
**Required fabric / Tessuto occorrente:** 1,10 m. (h 1,40).

## Rivoli

R

**Composition:** Ash wood structure, backrest and seat in curved plywood with expanded polyurethane foam, upholstered with fabric.  
**Composizione:** Struttura della base in massello di faggio, schienale e seduta in multistrato curvato, imbottiti con poliuretano espanso a quote differenziate, rivestiti in tessuto.  
**Weight / Peso:** 6,5 kg  
**Required fabric / Tessuto occorrente:** 1,10 m. (h 1,40).

## Macaron

**Weight / Peso:** 20 kg  
**Required fabric / Tessuto occorrente:** pouf complete 3,00 m. (h 1,40) only central cream 0,50 m. (h 1,40).

## Tonic

**Weight / Peso:** 8 kg  
**Required fabric / Tessuto occorrente:** 1,50 m. (h 1,40).

## Gin

**Weight / Peso:** 8 kg  
**Required fabric / Tessuto occorrente:** 1,50 m. (h 1,40).

## Drum

**Weight / Peso:** 9 kg  
**Required fabric / Tessuto occorrente:** 1,30 m. (h 1,40).

## Taco

**Weight / Peso:** 6 kg  
**Required fabric / Tessuto occorrente:** 2,00 m. (h 1,40).

## Adam

**Weight / Peso:** 8 kg  
**Required fabric / Tessuto occorrente:** 1,20 m. (h 1,40).

## Sky

**Weight / Peso:** from 6 to 15 kg  
**Required fabric / Tessuto occorrente:** 1,00 m. (h 1,40).

## Berg

**Weight / Peso:** from 5 to 10 kg  
**Required fabric / Tessuto occorrente:** 1,00 m. (h 1,40).

## Cloud

**Weight / Peso:** from 6 to 15 kg  
**Required fabric / Tessuto occorrente:** 1,00 m. (h 1,40).

## Vice-versa

**Weight / Peso:** from 9 to 47 kg  
**Required fabric / Tessuto occorrente:** da 1,10 m. a 3,30 m. (h 1,40)

## Moka

**Weight / Peso:** 8 kg  
**Required fabric / Tessuto occorrente:** 1,00 m. (h 1,40).

## Neep

**Weight / Peso:** 8 kg  
**Required fabric / Tessuto occorrente:** 1,30 m. (h 1,40).

## Noop

**Weight / Peso:** 12 kg  
**Required fabric / Tessuto occorrente:** 1,60 m. (h 1,40).

## Merge

**Weight / Peso:** 16 kg  
**Required fabric / Tessuto occorrente:** 2,00 m. (h 1,40).

## Ness

**Weight / Peso:** 3,5 kg  
**Required fabric / Tessuto occorrente:** 0,70 m. (h 1,40).

VOLUME 70

211

INNOVA

**Diamond**



01

02

03

**Option 1**

unique fabric

**Option 2**

one fabric for the outside backrest and another for the rest

**Option 3**

one fabric for the seat another for the backrest



**Tonic**

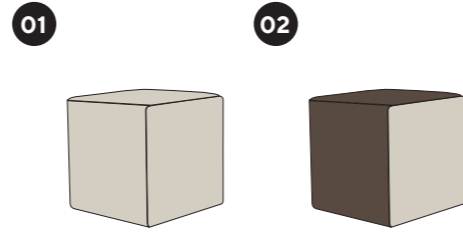

01

02

**Option 1**

unique fabric

**Option 2**

one fabric for the outside backrest and another for the rest



**Gin**

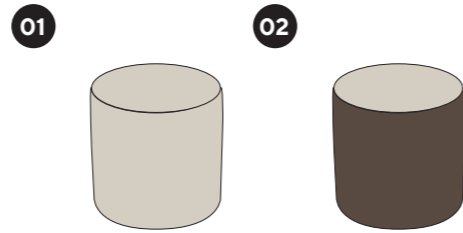

01

02

**Option 1**

unique fabric

**Option 2**

one fabric for the outside backrest and another for the rest

**Option 3**

one fabric for the seat another for the backrest



**Drum**

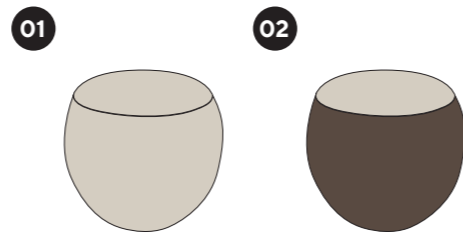

01

02

**Option 1**

unique fabric

**Option 2**

one fabric for the top and another for the bottom



**Taco**

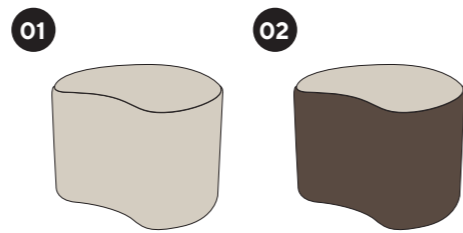

01

02

**Option 1**

unique fabric

**Option 2**

one fabric for the outside backrest and another for the rest

**Option 3**

one fabric for the seat another for the backrest



**Adam**

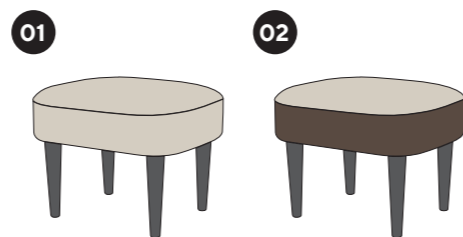

01

02

**Option 1**

unique fabric

**Option 2**

one fabric for the outside backrest and another for the rest



**Sky**



01

02

**Option 1**

unique fabric

**Option 2**

two different mixed fabrics



**Berg**



01

02

**Option 1**

unique fabric

**Option 2**

one fabric for the top and another for the bottom



**Cloud**



01

02

**Option 1**

unique fabric

**Option 2**

one fabric for the top and another for the bottom



**Neep & Noop**

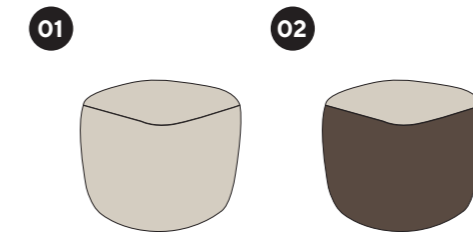

01

02

**Option 1**

unique fabric

**Option 2**

one fabric for the top and another for the bottom



**Merge**



01

02

**Option 1**

unique fabric

**Option 2**

one fabric for the top and another for the bottom

NB: piping will be the same colour as the outside fabric



**Option 1**

unique fabric

**Option 2**

one fabric for the top and another for the bottom



**Option 1**

unique fabric

**Option 2**

one fabric for the top and another for the bottom



**Option 1**

unique fabric

**Option 2**

one fabric for the top and another for the bottom



**Option 1**

unique fabric

**Option 2**

one fabric for the top and another for the bottom



**Option 1**

unique fabric

**Option 2**

one fabric for the top and another for the bottom



# Moka

Did someone say coffee table?  
Who better than Moka? Energy to exploit.

Qualcuno ha detto tavolino da caffè?  
Chi meglio di Moka? Energia da sfruttare.

VOLUME 7.0

VOLUME 7.0

241

242

INNOVA

INNOVA

## Tables



**TECHNICAL INFO**  
**Weight/ Peso:** 10 kg  
**Dimensions:** d. 41 cm h. 50 cm

# Tube

A play of round and elegant tubes supporting the top, available in different finishes..

È un gioco di tubi rotondi ed eleganti che sostengono il piano, in diverse finiture.

TABLES

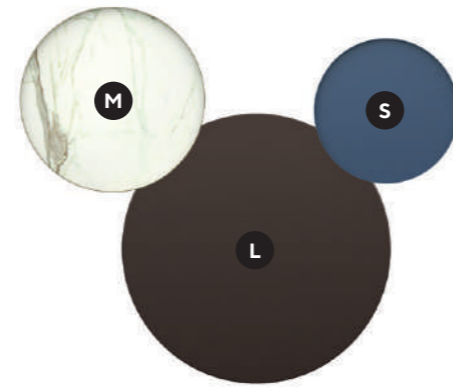

TAVOLINI

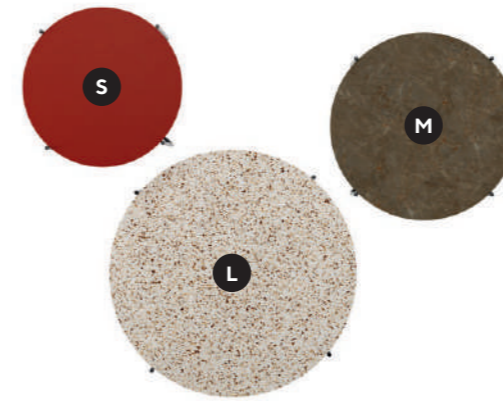

# Tulu

A linear and rigorous tubular base that rises up to support the top.

Un basamento lineare e rigoroso in tondino che sale a sostenere il piano.

VOLUME 7.0

VOLUME 7.0

243



INNOVA

## TECHNICAL INFO

**Weight/ Peso:** S 7 kg - M 9 kg - L 15 kg  
**Dimensions:** S d. 43 h. 46 cm  
M d. 55 h. 38 cm - L d. 80 h. 32 cm

244



INNOVA

## TECHNICAL INFO

**Weight/Peso:** S 5 kg - M 7 kg - L 10 kg  
**Dimensions:** S d. 50 cm h. 45 cm  
M d. 60 cm h. 35 cm - L d. 80 cm h. 30 cm

# Levante

A refined play between the arch that rises up and the cut of the horizontal line of the top.

Raffinato gioco tra l'arco che si leva e il taglio della linea orizzontale del piano.

TABLES

TAVOLINI

# Rosie

Rosie means to intersect two different souls within the same product, as the creative soul of an artist is enclosed in his person.

Rosie è intersecare due anime diverse all'interno di uno stesso prodotto, come l'anima creativa di un artista si racchiude nella sua persona.

VOLUME 7.0

VOLUME 7.0



245

246



INNOVA

INNOVA

## TECHNICAL INFO

**Weight/ Peso:** S 9 kg - M 9,5 kg - L 10 kg  
**Dimensions:** S d. 50 x 30 h. 50 cm  
M d. 50 x 40 h. 40 cm - L p. 50 x 50 h. 30 cm

## TECHNICAL INFO

**Weight/Peso:** M 13 kg - L 19 kg  
**Dimensions:** M 68x 68 cm - h. 44 cm  
L 88 x 88 cm - h. 34 cm

# Gio

Gio is a majestic but elegant presence, which embraces and softly supports its precious top.

Gio è una presenza imponente ma elegante, che abbraccia e sorregge con morbidezza il suo prezioso piano.

TABLES

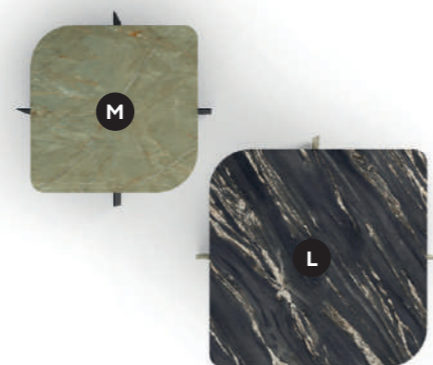

TAVOLINI

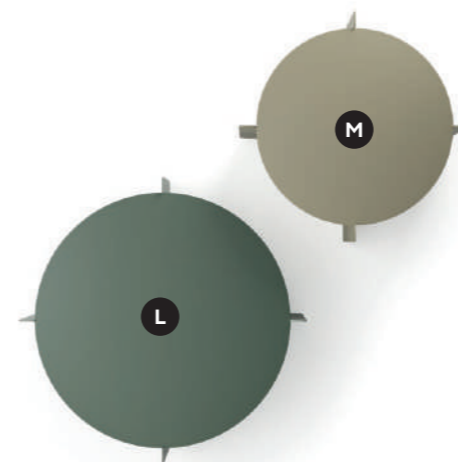

# Gio round

Gio is multitasking: with the round shape it became young, playfull and smart instead with the porcelain stoneware it is elegant and charming.

Gio è un prodotto poliedrico: con il piano tondo diventa giovanile, giocoso e smart mentre con il piano in gres è elegante e accattivante.

VOLUME 7.0

VOLUME 7.0

247



INNOVA

248

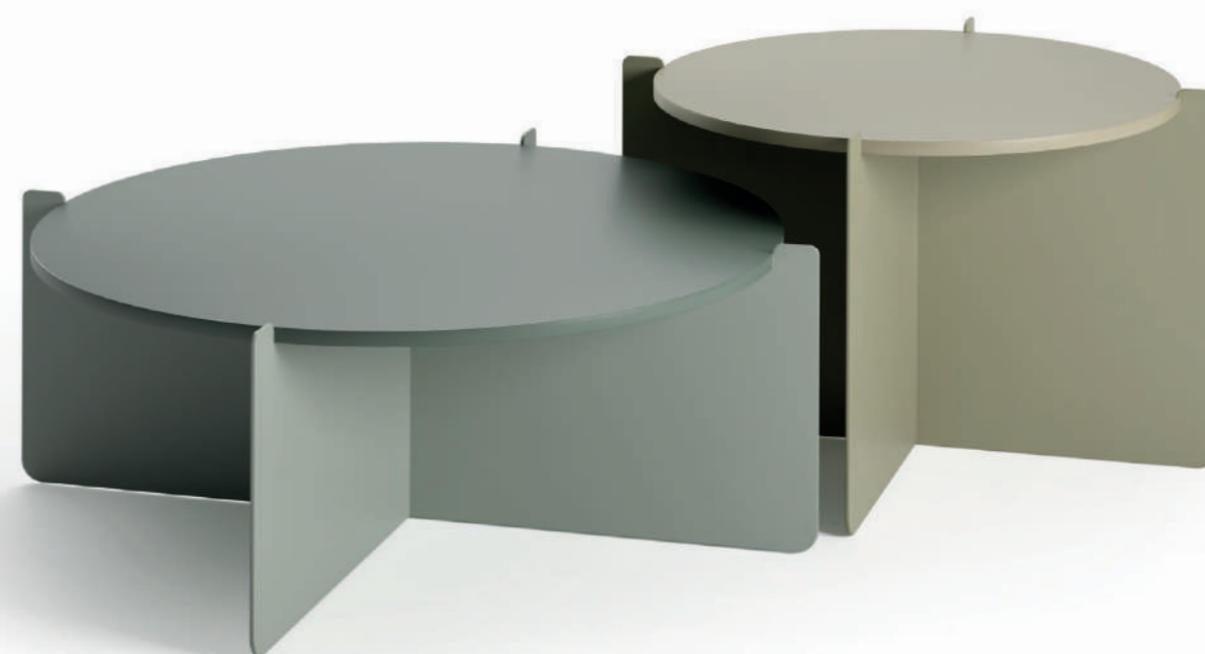

INNOVA

## TECHNICAL INFO

**Weight/Peso:** M 13 kg / L 19 kg  
**Dimensions:** M 68 x 68 cm - h. 44 cm  
L 88 x 88 cm - h. 34 cm

# Talino

The Tala collection is characterized by a design that skilfully blends lines and circles, creating an alternative way to elegantly support a surface.

La collezione Tala si caratterizza per un design che mescola abilmente linee e cerchi, creando un modo alternativo di sorreggere elegantemente un piano.

VOLUME 7.0

249



INNOVA

## TECHNICAL INFO

**Weight/ Peso:** M 9 kg - L 13 kg  
**Dimensions:** M d. 50 x h. 41 cm  
 L d. 80 x h. 36 cm

# Ness

Small or large, round or triangular, high or low, Ness coffee tables are as you wish them to be...

Piccoli o grandi, tondi o triangolari, alti o bassi, i tavolini Ness son come li vuoi tu...

VOLUME 7.0

250



INNOVA

## TECHNICAL INFO

**Weight/Peso:** S 4 kg - M 6,5 kg  
**Dimensions:** S d. 40 cm h. 39 cm  
 M d. 42 cm h. 68 cm

# Tala

Tala is a play of lines and circles that create a timeless sandglass, as a reminder that in certain situations there is no need to measure the time.

Tala è giochi di linee e cerchi che creano una clessidra senza tempo, a ricordare che in certe situazioni non c'è bisogno di misurarlo.



## TECHNICAL INFO

**Weight/ Peso:** 60 kg  
**Dimensions:** d. 120 h. 74 cm

TABLES

TAPPETI

Growing, Exploring and Innovating: this is our nature and for this reason, we wanted to get closer to a world similar to our reality and made of interweaving filaments, in order to maintain a common thread with who we are. We relied on the experience of those who have been professionals in this sector for more than 17 years to develop our design. Kymo believed in us and shared this journey together as a partner.

Crescere, Esplorare ed Innovare è nella nostra natura e per questo, mantenendo un filo conduttore con ciò che siamo, abbiamo voluto avvicinarci ad un mondo noi affine fatto di intrecci di filamenti. Per sviluppare il nostro design ci siamo appoggiati all'esperienza di chi è professionista nel settore da più di 17 anni. Kymo ha creduto in noi e ha condiviso questo percorso assieme come partner.

**innova**

*in partnership with*

**kymo**<sup>®</sup>

**carpets**

# Airy

Two lovers between lights and shadows, like the sun with the moon... get lost in the shades of Airy!

Due amanti tra luci e ombre come il sole con la luna... perditì nelle sfumature di Airy!

VOLUME 7.0

253

INNOVA



# Dori

The carefree way of mixing shapes, finishes and materials creates a bold design, free from any conventional form.

La spensieratezza nel mescolare forme, finiture e materiali crea un design audace, libero da ogni forma convenzionale.

VOLUME 7.0

254

INNOVA

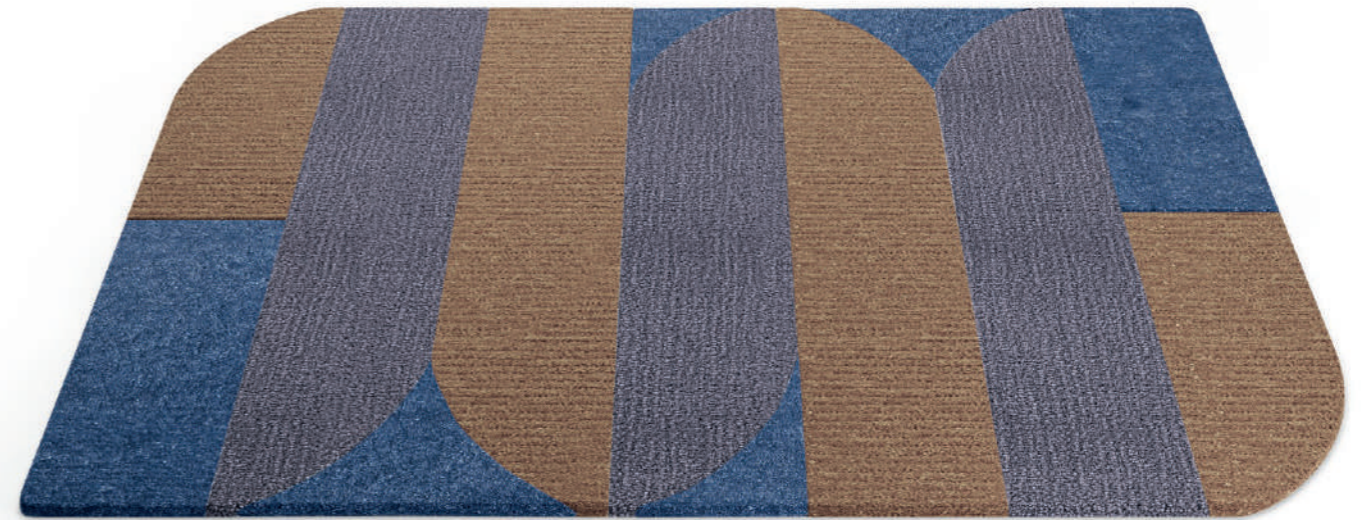

From the Innova family other families come out. They are the ones of our items, which live together harmoniously. It is a suggestion to furnish well-adjusted spaces, where the same lines and the same rhythm are used. Of course, it is just a suggestion: even the contrasting choices have their own reason. They create confusion or simply movement, such as when a new member arrive in the family and bring new strengths with him.

Dalla famiglia di Innova scaturiscono nuove famiglie. Sono quelle dei nostri prodotti che vivono in armonia fra loro. È una proposta per arredare ambienti equilibrati, che rincorrono lo stesso tipo di linee e di ritmo. Naturalmente è solo una proposta: anche le scelte a contrasto hanno il loro "perché". Creano scompiglio o semplice movimento, come quando in famiglia arriva un nuovo membro e porta nuove forze.

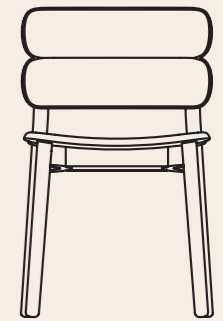
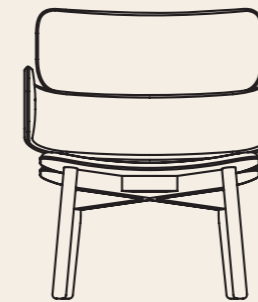
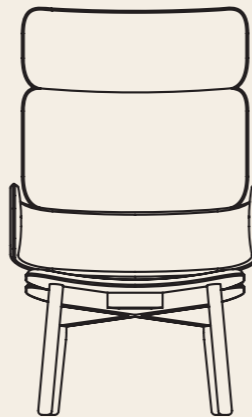
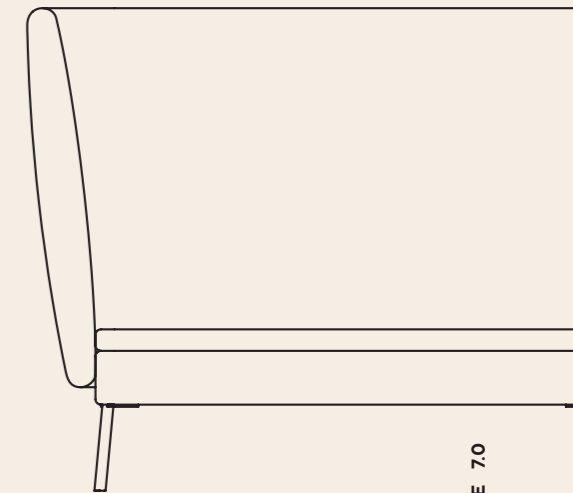
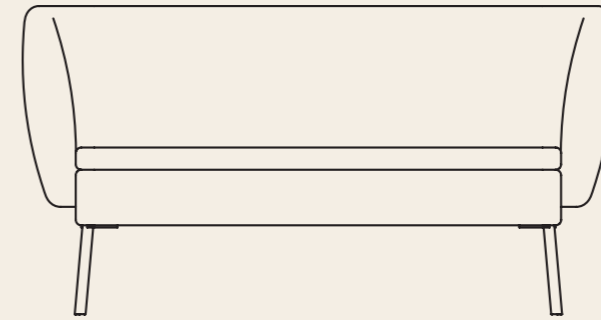
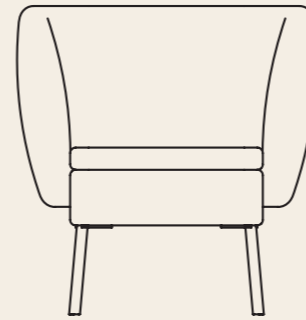

# families

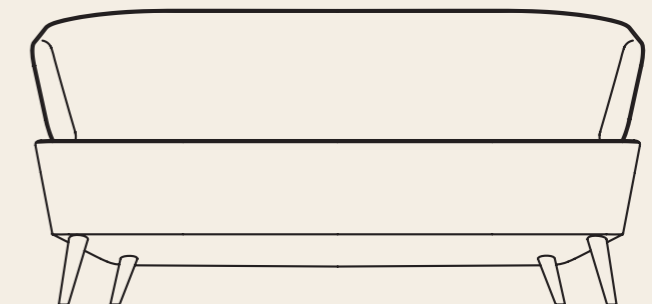
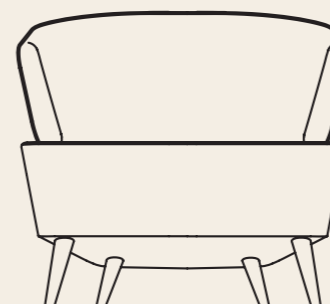
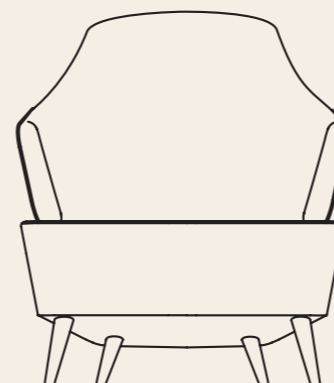
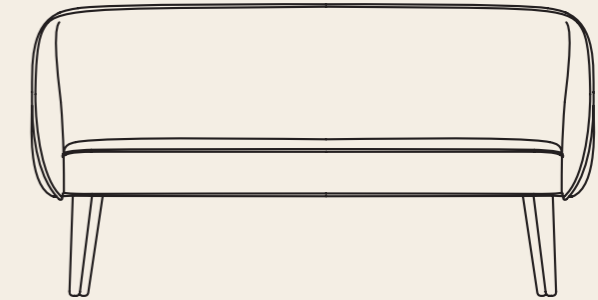
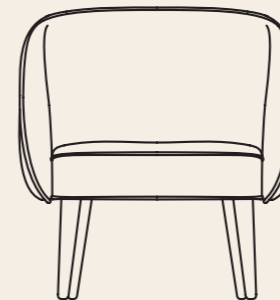
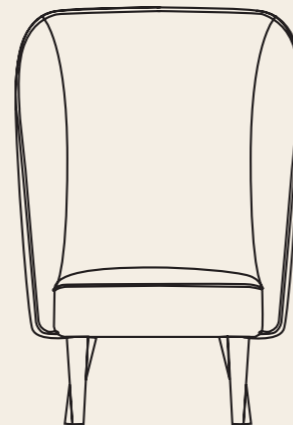

# Adam



P. 204



P. 100

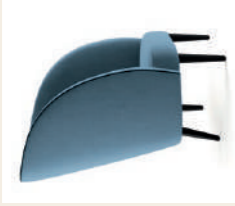

P. 102



P. 146

# Arsenale

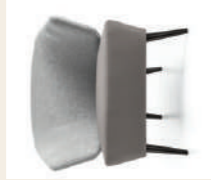

P. 124/126



P. 128

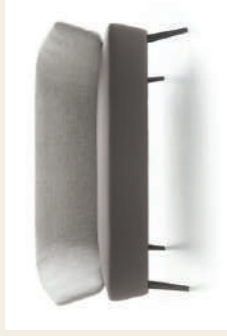

P. 154/156

# Bands



P. 34



P. 34



P. 104



P. 106

FAMILIES

# Berg



P. 205



P. 110



P. 110



P. 152

FAMIGLIE

# Bloom



P. 66



P. 66

# Bloom



P. 110

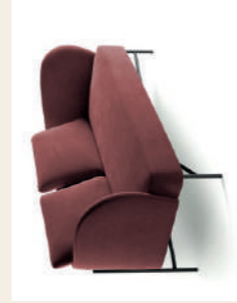

P. 158



P. 160

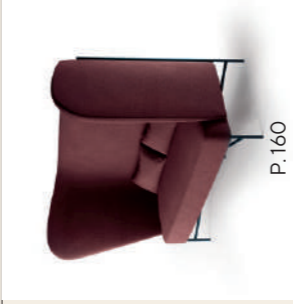

P. 160

# Circus



P. 56



P. 194

# Diamond



P. 38



P. 38



P. 120

# Eleven



P. 22



P. 22



P. 195



P. 195

# Izzy



P. 88



P. 150

# Kat



P. 122



P. 148



P. 148

# Kyo



P. 58



P. 58



P. 90



P. 196

# Look

FAMILIES



P. 134

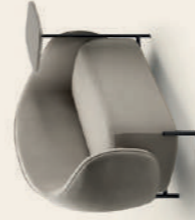

P. 172

FAMIGLIE

# Mella



P. 208

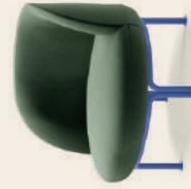

P. 138

# Merge



P. 132



P. 170

# Nobu

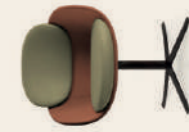

P. 70



P. 72

# Olie

# Rivoli



P.30



P.30



P.32



P.198



P.26



P.26



P.199

# Soho



P.206



P.186



P.206



P.186



P.186

# Vice-versa



P.78



P.80

# Woody

FAMILIES

FINITURE

# finishing

**WOOD STANDARD FINISHING /**  
FINITURE LEGNO STANDARD

**RAL COLOURS /**  
COLORI RAL

VOLUME 7.0

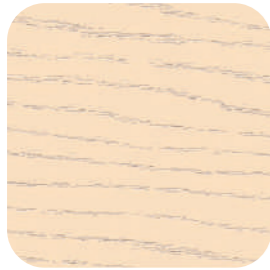

NATURAL/  
NATURALE

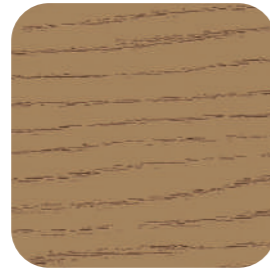

NATURAL OAK/  
ROVERE NATURALE



WENGÉ



BLACK/  
NERO



MEDIUM WALNUT/  
NOCE MEDIO



CANALETTO WALNUT/  
NOCE CANALETTO



DARK WALNUT/  
NOCE SCURO

263

**METAL STANDARD FINISHING /**  
FINITURE METALLO STANDARD

INNOVA



CHROME/  
CROMO



BLACK/  
NERO



BLUE

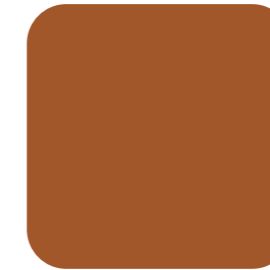

RUST



MUSTARD

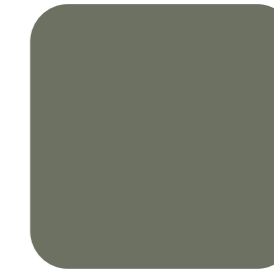

OLIVE

VOLUME 7.0

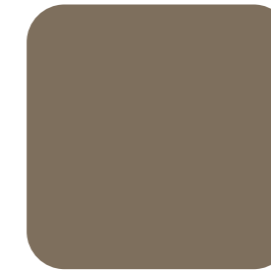

GREY BEIGE



GREY MILK



GREY SHADE

264

**SPECIAL FINISHING /**  
FINITURE SPECIALI



ASPHALT



CHAMPAGNE

INNOVA

FINISHING

FINITURE

**TABLES FINISHING /**  
FINITURE TAVOLINI

**PORCELAIN STONEWARE /**  
GRÉS PORCELLANATO

**TABLES MELAMINE COLOURS /**  
COLORI IN MELAMINICO TAVOLINI

**SOLID COLOURS /**  
TINTE UNITE

VOLUME 70



**CALACATTA VECCHIA**  
MACCHIA



**GREY MARBLE /**  
MARMO GRIGIO



**BLACK MARQUINIA /**  
NERO MARQUINIA

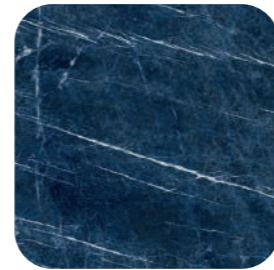

**SODALITE BLUE**



**CANALETTO**



**PULPIS BRONZE**

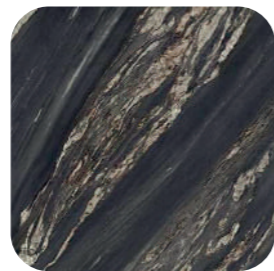

**TROPICAL BLACK /**  
NERO TROPICALE

265

**TABLES MELAMINE FINISHING /**  
FINITURE IN MELAMINICO TAVOLINI

**STONES AND RESINS /**  
PIETRE E RESINE

**TABLES MELAMINE FINISHING /**  
FINITURE IN MELAMINICO TAVOLINI

**ENDGRANI WOOD /**  
EFFETTO LEGNO

VOLUME 70

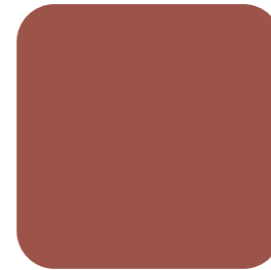

**CERAMIC RED**

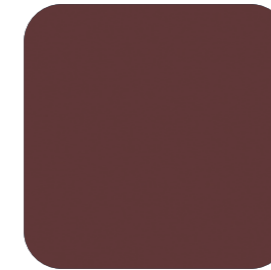

**ACAI BROWN**



**OLIVE GREEN**

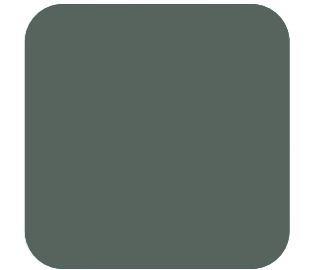

**GREEN**



**GRAPHITE BLUE**



**TAUPE**



**DARK BROWN**

266

INNOVA

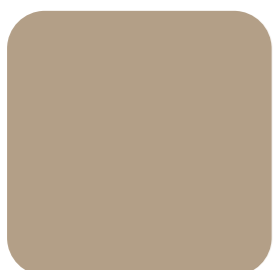

**BEIGE CEMENT /**  
CEMENTO BEIGE



**OXIDE BRONZE /**  
OSSIDO BRONZO



**CLASSIC OAK /**  
QUERCIA CLASSIC



**TAUPE OAK /**  
QUERCIA TAUPE

INNOVA

If you like what you have seen up to here, you have appreciated a mix of ideas, work, passion and concepts to which many people have contributed. Because ideas and people come first, before any action of marketing and communication. The idea precedes even those who thought it up. And when it impresses, it becomes objectively interesting, regardless of where it came from. For this reason, we decided to de-personalise our designers and represent them in a cartoon graphic, since the ideas are more important than the names – familiar or not – of their designers.

Se quello che hai visto fino a qua ti è piaciuto, hai apprezzato un mix di idee, lavoro, passione e concetti al quale hanno contribuito svariate persone. Perché le idee e le persone vengono prima, prima di ogni azione di marketing e di comunicazione. L'idea precede, addirittura, chi l'ha pensata. E se colpisce, diventa oggettivamente interessante, a prescindere da chi l'abbia avuta. Per questo motivo abbiamo deciso di depersonalizzare i designer e rappresentarli in maniera graficamente cartonata poiché le idee sono più importanti del nome, conosciuto o meno, del loro designer.

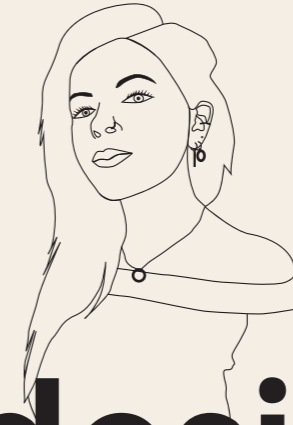
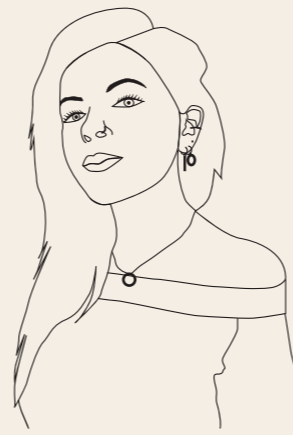

# design feel

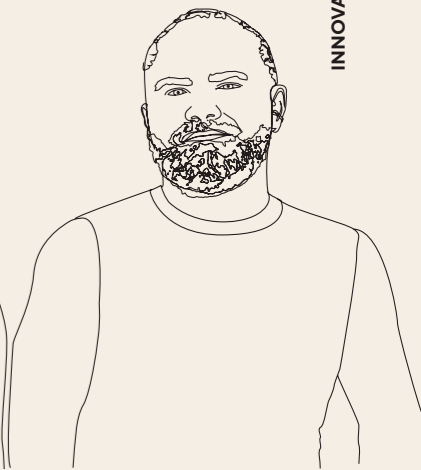
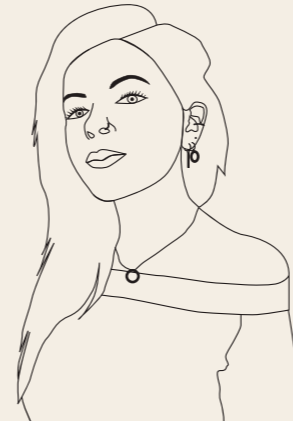

# The designers

Ideas come first branding, we believe that no matter what but peoples and design comes before any action of marketing and communication.

L'idea viene prima del brand, a qualunque costo noi crediamo che le persone ed il design vengono prima di ogni azione di marketing e comunicazione.



## Antonio Fattore

Designer

He holds a degree in Design from the IED in Milan in 2014. His furnishings combine contemporary aesthetic taste with the formal suggestions deriving from his multidisciplinary background and in-depth studies of manufacturing processes.

Diplomatosi in Design allo IED di Milano nel 2014, progetta arredi in grado di coniugare il gusto estetico contemporaneo e le suggestioni formali derivanti dal suo background multidisciplinare e dai suoi studi approfonditi dei processi produttivi.

**Projects: Arsenale, Circus, Nobu**

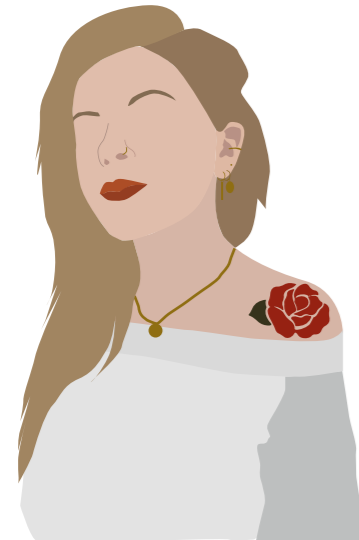

## Eleonora Barillari

Art director

After graduating, she immediately focuses on furniture design, dealing with artistic direction and product design. Her work has a design line based on a people-focused and extremely artistic approach. She has a young, lively and future-oriented design vision.

Dopo la laurea, si dedica immediatamente al furniture design, occupandosi di direzione artistica e di design del prodotto. Il suo lavoro ha un approccio progettuale focalizzato sulla persona ed estremamente artistico. Una visione di design young, vivace e proiettato al futuro.

**Projects: Mies, Vice-versa, Brezza, Rosie, Gio, Dori, Crabby**



## Mirco Cavallo

Architect

In 1999 he founded his own studio SuperStudio21 in Cologne, Germany. His studio deals with various themes, from Architecture to Design, from Graphics to Art; all disciplines that involve experimentation and love for one's work.

Nel 1999 fonda il suo studio SuperStudio21 a Colonia in Germania. Il suo studio affronta diverse tematiche, dall'Architettura al Design, dalla Grafica all'Arte; discipline che implicano sperimentazione ed amore per il proprio lavoro.

**Projects: Moka**



## PARK Associati

Architects

Founded in 2000 by Filippo Pagliani and Michele Rossi, Park Associati focuses on architecture, urban planning, landscape, interior design and product design. At the studio, design is an open process that feeds on dialogue and combines analysis and intuition.

Fondato nel 2000 da Filippo Pagliani e Michele Rossi, Park Associati si occupa di architettura, urbanistica, landscape, interior design e product design. Nello studio, la progettazione è un processo aperto che si nutre di dialogo e combina analisi e intuizione.

**Projects: Mella Collection**

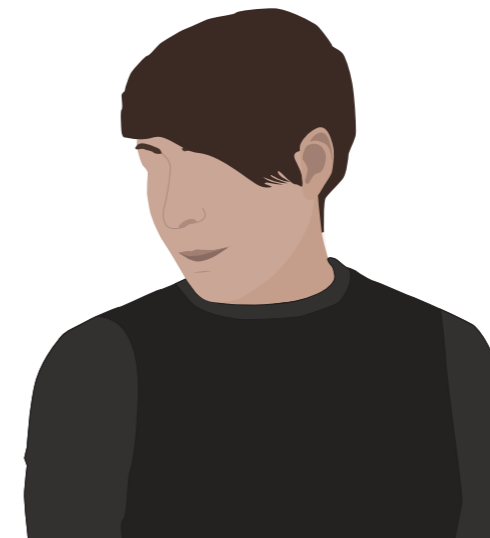

## Fabrizio Citton

Designer

Designer and founder of Arter&Citton, an architecture and design practice. His design work extends into various fields, such as architecture, design, interior design, communication and visual selling.

Progettista, fonda lo studio Arter&Citton, che si occupa di architettura e design. È attivo nella progettazione estesa in varie aree disciplinari, quali l'architettura, il design, l'interior design, la comunicazione e il visual selling.

**Projects: Kat, Adam, Kyo, Sgabby, Bisu**

# The designers

Ideas come first branding, we believe that no matter what but peoples and design comes before any action of marketing and communication.

L'idea viene prima del brand, a qualunque costo noi crediamo che le persone ed il design vengono prima di ogni azione di marketing e comunicazione.



**Monica Graffeo**

Designer

She has been involved in design since 1997 with a strong multidisciplinary vocation. Since this time she has been involved in product development and art direction, working with numerous furniture companies, from bathrooms to decorative objects, to office and home furnishings.

Si occupa di design dal 1997 con una spiccata vocazione multidisciplinare. Ha da allora collaborato, occupandosi di sviluppo prodotto e di direzione artistica, con numerose aziende dell'arredo, dal bagno all'oggettistica, dall'ufficio alla casa.

**Projects:** Bands collection

**DON'T  
DESIGN  
FOR  
DESIGNERS.**

**DESIGN FOR  
PEOPLE.**

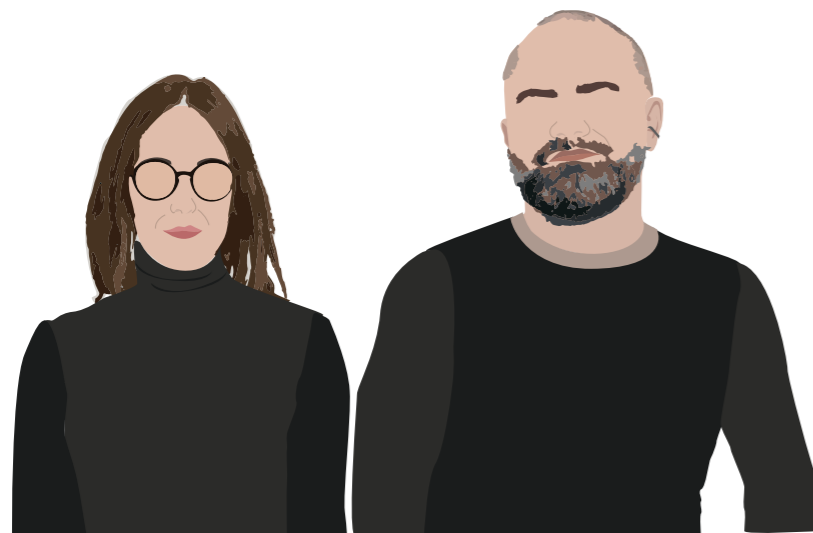

**STORMO studio**

Designers

Italian design studio, focused on the relationship between design and people, works on projects of various scales, from product design to artistic direction, encompassing interiors, exhibitions, and installations. Stormo Studio is led by Elena Calabrò and Michael Carion.

Studio di design Italiano, focalizzato sul rapporto tra design e persone lavora su progetti di varia scala, dal design del prodotto alla direzione artistica, comprendendo interni, mostre ed installazioni. Stormo studio è diretto da Elena Calabrò e Michael Carion.

**Project:** Merge

**INNOVA Srl**

Via Meucci, 17 - 35011 Campodarsego (PD) - Italy  
tel. +39 049 9200500

commerciale@innovaimbottiti.com  
**www.innovaimbottiti.com**

